

EDN

SEPTEMBER 2014

www.edn-europe.com

Issue 8

europe

- 
- Consumer connections toughen up for automotive infotainment – [page 12](#)*
- Vehicle designs need 65V step-down converters, and very low I_Q – [page 14](#)*
- Transform slow software into fast hardware with high level synthesis – [page 16](#)*
- What about DC Power Integrity? - Part 2 – [page 25](#)*
- SATA 6G signal quality assessed vs SSD benchmarks – [page 27](#)*
- The G word: How to get your audio off the ground (Part 2) – [page 28](#)*



6 – 18 GHz power divider /combiner

The abstract-art forms on the cover image belong to a Wilkinson power divider from the Dielectric Laboratories (DLI) facility of Knowles Capacitors. It provides in phase power splitting or combining over a broad bandwidth in low power applications. The device is constructed using precision thin film fabrication with integrated resistors, and can replace both packaged MMIC based solutions as well as larger dividers integrated into printed wiring boards. It offers return loss and isolation of typically 20 dB or better throughout the band of operation while the mid band insertion loss is typically 0.4 dB. See item [here](#).

FEATURE ARTICLES

- 12. Consumer connections toughen up for automotive infotainment**
by Deres Eshete, ON Semiconductor
- 14. Vehicle designs need 65V step-down converters, and very low I_o**
by Jeff Gruetter, Linear Technology
- 16. Transform slow software into fast hardware with high level synthesis**
by David C. Black, Doulos
- 25. What about DC Power Integrity? - Part 2**
by Benjamin Jordan, Altium
- 27. SATA 6G signal quality assessed vs SSD benchmarks**
by Hermann Ruckerbauer, EKH – EyeKnowHow
- 28. The G word: How to get your audio off the ground (Part 2)**
by Bruno Putzeys

Departments and Columns

EDN. COMMENT

- 4 M&A season

BAKER'S BEST

- 13 The inner workings of the three-op-amp INA
by Bonnie Baker

Analog Tips

- 13 Lock-in amplifier
by Jason Boudreau, Analog Devices

TEAR DOWN

- 26 1966 Programmable scientific calculator
by Michael Dunn, EDN

TALES FROM THE CUBE

- 36 If you can't have the parts you want, use the parts you have
Michael Allen

product roundup

- 32 RF & Bluetooth ICs; Industrial/motor control MCUs; Arduino libraries for HMIs

DESIGN IDEAS

- 29 Add phases to simple RC oscillator
- 30 Improve efficiency of low-cost switcher
- 31 Avago Tech Note: Isolated current sensing with Σ - Δ optoisolators

pulse

- 6 Free software tool provides circuit simulation and PCB layout
- 6 First DDR4 NVDIMM sampling: Flash-backed DRAM
- 7 USB-to-Internet connects stand-alone devices
- 7 "Desktop PCB factory" turns a design into a working circuit in 30 minutes
- 7 Is free-space wireless charging viable? Dialog thinks so
- 8 New books; embedded-interface design, and the IoT surveyed
- 8 Webinar on Software Testing; "Test Like Google"
- 10 RSA encryption for embedded systems counters design cloning
- 10 Audi makes the leap to (partial) 48V supply
- 10 Single-chip, global coverage car radio receiver
- 11 Off-the-shelf embedded USB host stack for FTDI's MCUs
- 11 MIPS Warrior core IP: 64-bit processing scales from mobile to high-end servers

EDN

SEPTEMBER 2014

www.edn-europe.com

Issue 8

europe

CONTACTS

PUBLISHER

André Rousselot

+32 27400053

andre.rousselot@eetimes.be

EDITOR-IN-CHIEF

Graham Prophet

+44 7733 457432

edn-editor@eetimes.be

Patrick Mannion

Brand Director EDN Worldwide

CIRCULATION & FINANCE

Luc Desimpel

luc.desimpel@eetimes.be

ADVERTISING PRODUCTION & REPRINTS

Lydia Gijsegom

lydia.gijsegom@eetimes.be

ART MANAGER

Jean-Paul Speliers

ACCOUNTING

Ricardo Pinto Ferreira

EUROPEAN BUSINESS PRESS SA

7 Avenue Reine Astrid

1310 La Hulpe

Tel: +32 (0)2 740 00 50

Fax: +32 (0)2 740 00 59

www.electronics-eetimes.com

VAT Registration: BE 461.357.437

RPM: Nivelles

Company Number: 0461357437

© 2014 E.B.P. SA



EDN-EUROPE is published 11 times in 2014 by European Business Press SA, 7 Avenue Reine Astrid, 1310 La Hulpe, Belgium
Tel: +32-2-740 00 50 Fax: +32-2-740 00 59
email: info@eetimes.be. VAT Registration: BE 461.357.437.
RPM: Nivelles.

It is free to qualified engineers and managers involved in engineering decisions – see:

<http://www.edn-europe.com/subscribe>

Copyright 2014 by European Business Press SA.

All rights reserved.

SALES CONTACTS

Europe

Daniel Cardon

France, Spain, Portugal

+33 688 27 06 35

cardon.d@gmail.com

Nadia Liefsoens
Belgium

+32-11-224 397

n.liefsoens@fivemedia.be

Nick Walker

UK, Ireland, Israel,
The Netherlands

+44 (0) 1442 864191

nickjwalker@btinternet.com

Victoria & Norbert Hufmann

Germany, Austria,
Eastern Europe

+49 911 93 97 64 42

sales@hufmann.info

Monika Ailinger

Switzerland

+41-41-850 4424

m.ailinger@marcomedia.ch

Andrea Rancati

Italy

+39-02-284 6716

info@silvera.it

Colm Barry & Jeff Draycott

Scandinavia

+46-40-41 41 78

jeff.draycott@womp-int.com

colm.barry@telia.com

USA & Canada

Todd A. Bria

West

+1 831 477 2075

tbria@globalmediasales.com

Jim Lees

PA, NJ & NY

+1-610-626 0540

jim@leesmedia.com

Steve Priessman

East, Midwest,
South Central

& Canada

+1-630-420 8744

steve@stevenpriessman.com

Lesley Harmoning

East, Midwest,
South Central

& Canada

+1-218.686.6438

lesleyharmoning@gmail.com

Asia

Keita Sato

Japan

+81-3-6824-9386

Mlshida@mx.itmedia.co.jp

Grace Wu

Asian Sources Publications

Asia

(886-2) 2712-6877

wug@globalsources.com

John Ng

Asian Sources Publications

Asia

(86-755) 8828 – 2656

jng@globalsources.com

M&A SEASON

August brought a spate of M&A (mergers and acquisitions) activity in the semiconductor industry, two of the announcements having a European aspect. First to be announced was the bid by Infineon Technologies for International Rectifier. Infineon announced that it intends to acquire International Rectifier, paying \$3 billion for the company. At \$40 per IR share, a premium of around 50% to the immediately-prior share price, the board of IR could do little other than agree the bid, and it will be completed late in 2014 or early 2015, subject to the usual approvals. This puts together both companies' strong presence in sectors such as power MOSFETs; Infineon has considerable mixed-signal/power integration expertise but will now add IR's capabilities in integrated, multi-chip modules. Infineon refers to IR's "system know-how in power conversion" - both companies are strong players in the power-management IC sector - as well as its expertise in compound semiconductors (Gallium Nitride on Silicon). Infineon has worked in both silicon carbide and GaN - in terms of silicon-alternative technologies - but IR declared early for the GaN-on-silicon route and has a growing product offering in that technology. Infineon also refers to economies of scale to be gained by merging the manufacturing of both companies' product lines, although to what extent this produces real returns will only become apparent over time. Manufacture of discretes and power devices is characterised by diverse product ranges with, often, small dice, and the total silicon area of any one product line is often not such as to realise an instant benefit from semiconductor production scale-ups. For the highest volume/biggest dice product lines, the joining of Infineon and IR may enable an earlier shift to production on larger (300 mm) wafers. Infineon may also be looking to load its Dresden fab, to get that investment working productively. The acquisition closes an almost-70-year history in the industry; IR was founded by Eric Lidow in the late 1940s, making it one of the oldest semiconductor companies. Lidow died only recently, at the age of 100. Not a few commentators have noted the ironic aspects of the story, in that Lidow fled Germany in the 1930s, arriving in the US with only a few dollars to his name. He built an enterprise from the ground up, and in time it is acquired by a German company from an utterly different age. In some ways, it is "the American dream".

A different international dimension applies to the next case; Murata and Peregrine have announced that Murata will acquire Peregrine Semiconductor for \$12.50 per share in cash, or a total transaction value of \$471 million. Murata being a Japanese corporation, and Peregrine having roots in Australia, although today its centre-of-gravity is in the US. Peregrine pioneered use of CMOS silicon-on-insulator techniques for RF front-end functions, particular under its UltraCMOS brand. The company has created a number of product categories around its ability to fabricate low-loss, high-isolation RF switches, with very high linearity, in CMOS; for example, antenna switches, multi-step attenuators, digitally tuned capacitors and filters. Its products have admitted CMOS to several functions that previously were only achievable using III-V semiconductors. Most recently, it has combined several strands of its product line - switches, filters, and CMOS amplifiers - to produce Global 1, a fully-CMOS, silicon-on-insulator, integrated front-end for mobile handsets, spanning all worldwide bands. And, its MPAC product has offered a route to increasing the usability of the dual-path Doherty amplifier topology.

Murata sells a number of technologies into the mobile handset and infrastructure sector, notably RF modules and filters, including an established SAW filter capacity. This acquisition expands Murata's RF front-end capabilities, in both active and passive devices, and adds advanced silicon-on-insulator and silicon-on-sapphire capabilities to its portfolio. As well as offering technologies for the mobile-devices sector, Peregrine supplies other wireless markets, including test & measurement, automotive, public safety radio and wireless infrastructure. Murata also gains Peregrine's portfolio of Intellectual Property Rights (IPR) covering the entire RF SOI front-end. This acquisition will be completed in late 2014 or early 2015.

There's a European dimension to the third M&A story of the last few weeks; Cirrus Logic completed its takeover Wolfson Microelectronics. The Texas-based company announced its intention to acquire Wolfson in April 2014, and secured the agreement of Wolfson's Board and shareholders, with an offer of £2.35 per share in cash, implying an enterprise value of £278 million, or approximately \$467 million. A final value for the deal is quoted at £291 million. Cirrus Logic says it strengthens the company's position in audio ICs and software for portable applications.

Wolfson Microelectronics was originally a spin-out from Edinburgh University's Wolfson Microelectronics Institute, in 1984, founded by David Milne and Jim Reid. In its early phase the company focussed on ASIC designs, later taking the expertise it had gained in mixed-signal design into creation of its own range of ASSPs. These are particularly targeted at audio and multi-media functions, securing high-profile design wins for high-quality audio functions in high-volume smartphones, tablets and other portable devices. Wolfson has also developed a MEMS design capability with which it builds MEMS microphones.

For the management of each of these enterprises - and not only on the buying side of the deal - the real work now begins. Handling the integration of one company into another is notoriously difficult, and there are many quotes in the M&A business to the effect that few mergers ultimately deliver shareholder value. Warren Buffet is often quoted as saying that too many CEOs believe that they have the power of a fairy-tale prince, to deliver a magic kiss that will transform (corporate) toads. In the cases of IR, Peregrine and Wolfson, none of them are "toads": far from it - none of them needs to be transformed.

In the statements that accompany M&A announcements, perhaps the most over-used word is 'synergy' - the potential to take the assets of both acquired and acquirer, and make something more than the sum of the parts. It's a fine aspiration, there are many ways of going about it, and most of the pitfalls are about people. You can aim for a complete integration, absorbing one company into the other. One of the risks of that approach is that key people, who had status prior to the merger, feel lost in the larger enterprise. Or, you can run the acquired company as a (mostly) autonomous subsidiary, risking the people that matter feeling isolated on the periphery of the operation. Get it right, finesse the integration process just-so, keep hold of the core staff of the company you bought and renew their enthusiasm - and two-plus-two can indeed make much more than a corporate 'four'.

Your Partner in Automotive Wireless Testing

Wireless applications like eCall, car2car, driver assistance, cellular communications and wireless links have become ubiquitous in vehicles today.

Rohde & Schwarz supports manufacturers and suppliers with T&M solutions for developing and producing driver assistance and information systems, A/V components and wireless communications systems.

Your advantages:

- ▮ Worldwide development, sales and service network
- ▮ Unrivalled portfolio of T&M solutions for all wireless technologies
- ▮ Member of international standardization bodies



pulse

Free software tool provides circuit simulation and PCB layout

Distributor Mouser is to release the MultiSIM BLUE software package, based on code by National Instruments; the NI Multisim Component Evaluator - Mouser Edition. In collaboration with NI, this Mouser version of the free tool will add features and functionality to provide engineers with an industry-standard SPICE simulation environment of electronic circuits using Mouser Electronics' distributed components. This forthcoming release of MultiSIM BLUE will include more than 100,000 electronic components with intuitive simulation features and SPICE analyses. You can visualise and evaluate linear performance, making this critical step of circuit design easier, faster and far more productive. With MultiSIM BLUE, you can create schematics, simulate circuits and build printed circuit board

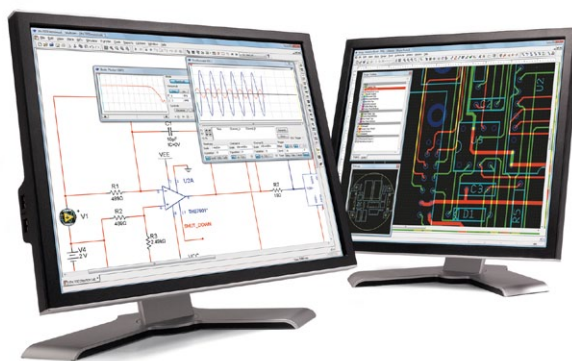

layouts, all with one integrated tool. MultiSIM BLUE gives the ability to scheme and simulate, plus it handles PCB layout, Bill of Materials (BOM) and purchasing. The circuit design tool is included with a library of more than 100,000 authorised Mouser electronic components. Simulation is driven by the same advanced parser technology as NI Multisim software with support from BSIM and other advanced parameters. Circuit diagrams can be defined with up to 50 components. The package supports a wide range of component types including passives, discretes, analogue ICs, discrete signal ICs, mixed signal

ICs, sensors, power ICs and protection devices.

A video is available [here](#).

Complete article, here



First DDR4 NVDIMM sampling: Flash-backed DRAM

AgigA Tech, a subsidiary of Cypress Semiconductor, and a provider of high-speed, high-density, and battery-free nonvolatile memory solutions, has announced that it is now sampling the first DDR4 Nonvolatile DIMM (NVDIMM) to OEMs and development partners. The AGIGARAM DDR4 NVDIMM has been designed to operate in the standard DIMM sockets of next-generation, Intel-based server platforms, providing a significant boost to I/O performance in a host of applications, including storage and database acceleration.

AGIGARAM is a new class of nonvolatile memory developed to meet the need for higher-performance persistent memory for enterprise-class storage and server applications. By combining industry-standard DRAM and NAND Flash technology, AGI-

GARAM provides the low latency and nearly infinite endurance of DRAM, along with the nonvolatility of Flash. During normal operation, the AGIGARAM DDR4 NVDIMM appears to the host system as a standard JEDEC 288-pin Registered ECC DIMM.

In the event of an unexpected power loss, the critical data residing in the DRAM is saved to onboard NAND Flash using a battery-free power source based on ultracapacitors. Alternatively, the

NVDIMM can also be powered over the JEDEC-defined 12V power pins on the DIMM interface. When system power is returned, the in-memory state of the DRAM at the time power was lost is restored from the Flash. The recovery time from a catastrophic power-loss event is almost immediate since the restore operation takes a matter of seconds and recharging the ultracapacitors takes only minutes.



Complete article, here



USB-to-Internet connects stand-alone devices

Segger, supplier of embedded systems development tools, has announced a complete USB to Internet solution that uses the RNDIS USB class. It enables developers to transform low-end stand-alone products into connected devices with the same functionality as other devices on a local network. The company says that its emUSB-Device PRO and embOS/IP PRO packages form the first complete out-of-the-box solution for accessing stand-alone USB devices with standard Internet services such as a Web browser. With an appropriate application server in the firmware of a USB-connected device, any internet service on the host computer can access it. Examples



include Web, Telnet, FTP or other application-specific services. emUSB-Device is a high performance USB device stack specifically designed for embedded systems. The flexible device stack allows the creation of multi-class devices using nearly any combination of the classes provided. The host can allow the USB device to access the LAN and Internet if desired. If the USB device is capable of accessing the Internet, such as an internet access stick, it can allow host access as well. Installation of an additional USB host driver is not necessary and the technology can be used on micro-controllers with as little as 128 kB of flash.



“Desktop PCB factory” turns a design into a working circuit in 30 minutes *by Lee Goldberg, EDN*

What would you do if you could turn the schematic you sketched on the back of a napkin during your lunch break into a fully-assembled circuit before your afternoon coffee break? What would you do if you could print a circuit which monitored your vital signs onto a flexible circuit board which could be easily sewn into your workout clothes? These, and many other “what-if?” scenarios may be answered by Squink, a \$3000 “screen-to-machine” desktop electronics factory, after it completes its recently-launched crowd-funding campaign on Kickstarter. One glance at Squink is all it takes to see how much of its innards have been cleverly adapted from the 3D printer world. Both of Squink’s X-Y stages use a ball screw drive system favoured by many 3D printers, with the element which would normally hold the print head moving along one axis, and the platform which holds the circuit board along the other. The tool head also moves in the Z direction. Instead of a 3D printer’s print head, Squink has a tool holder which can accept three interchangeable heads. A video of Squink in action is [here](#).

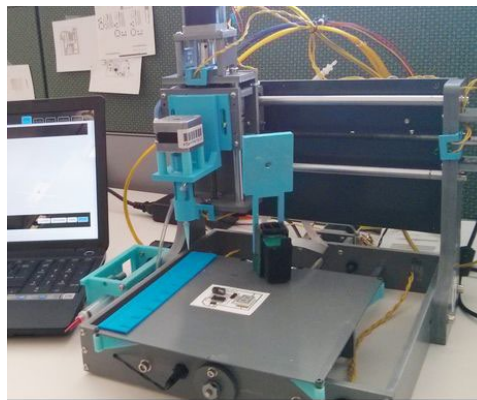

As shown in the video above, the first head deposits the conductive ink on the circuit board material, guided by either GERBER RS-274X files or uploaded PNG, JPG or BMP files.

Once the conductors are laid, the conductive ink cartridge is swapped out for a conductive glue dispenser. Squink can use a standard soldermask file, typically generated by your CAD tool, to place dots of conductive adhesive at every place where a part will need to be connected. The third head is a vacuum pick-up assembly which can be used to select a component from a holding tray and place it on the proper set of adhesive-primed contacts. If desired, the adhesive can be quickly set with an optional 15-minute heat-curing cycle.

The machine being offered on Kickstarter can fabricate printed circuits up to 5 x 5 in. (~25 x 25 cm). It’s estimated that it will take Squink about 30 minutes to print a 10 x 10-cm PCB and place 15 components on it.



Is free-space wireless charging viable? Dialog thinks so

Dialog Semiconductor and Energous are to collaborate to develop market for Energous’ “Wattup” wire-free charging technology; the two companies aim to bring a combination of over-the-air wireless charging, and lowest power Bluetooth Smart, to wearable IoT devices. Energous’ technology promises charging of devices such as Smartphones, within a room or within around 3m of a charging point, with no connections to the hand-held or wearable device and with no requirement to lay it on a charging pad or mat.

Details of Energous’ exact technology have so far been sketchy, but the company says it is using “the same radio bands” as WiFi and other wireless communications standards – therefore, GHz RF. Within the operational range of the charging point (Energous calls the space a “pocket”) a compatible device is found and authorised for charging. Once identified, a phased-array of transmitting antennae form an RF beam that is focussed on the target device, and that tracks it if it moves. That RF is received, rectified and used as the power source. Questions that will im-

mediately occur to engineers include, how much power can actually be delivered in this way – a figure of 10W has been seen but it is not clear if this is the power available, or transmitted. And; what end-to-end efficiency is possible? Reported figures of 20% (mains-socket to battery terminal) for prototypes have been mentioned, with Energous expressing confidence that this can be raised. Inevitably, questions of safety will arise, even if power levels are modest. Energous is playing in a space where [Witricity](#) has already staked a claim; this MIT spin-off company proposed magnetic resonance rather than RF as a means of sending power over a free-space distance (a standard called [Rezence](#) has support from some high-profile names) and has been associated with

higher power levels such as EV and HEV charging. The deal with Dialog is specifically targeted at “wearables” and may therefore fit in a niche where required power levels are low, modest efficiency is acceptable and safety concerns minimised. The formal announcement says that; Dialog Semiconductor has agreed to a joint collaboration with Energous Corporation, developer of WattUp, a disruptive wire-free charging technology for electronic devices that provides power at a distance with complete mobility under full software control. Dialog and Energous will develop reference designs to engage customers and further evaluate the market for wire-free power.



New books; embedded-interface design, and the IoT surveyed

Graphics, Touch, Sound and USB, User Interface Design for Embedded Applications’ by Lucio Di Jasio, leads designers of all abilities through a series of hands-on projects to explore the full potential of rich multimedia user interfaces with 16- and 32-bit microcontrollers. The



book’s author is a PIC expert at Microchip Technology and the author of a number of books on programming and developing embedded applications with PIC microcontrollers.

The series of projects presented in the book gradually increases in complexity, enabling

- readers to learn how to design compelling user interfaces for their embedded applications by:
- Interfacing to TFT colour graphics displays
 - Detecting and decoding touch screen inputs
 - Adding sound to provide end-users with quality audible feedback
 - Handling multiple fonts and images to maximise visual impact
 - Storing and retrieving data from serial Flash devices and micro-SD cards.

The book also explains how to create HID-class custom devices and CDC-class virtual serial ports which avoid the need to

design drivers when adding Full Speed USB for connectivity to personal computers and other devices.

More [here](#)

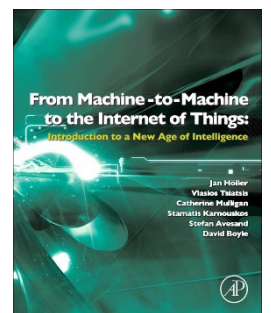

The Academic Press division of publishers Elsevier has issued **“From Machine-to-Machine to the Internet of Things: Introduction to a New Age of Intelligence”**; This book outlines the background and overall vision for the Internet of Things (IoT) and Machine-to-Machine (M2M) communications and services, including major standards.

Key technologies are described, and include everything from physical instrumentation of devices to the cloud infrastructures used to collect data. Also included is how to derive information and knowledge, and how to integrate it into enterprise processes, as well as system architectures and regulatory requirements. Real-world service use case studies provide the hands-on knowledge needed to successfully develop and implement M2M and IoT technologies sustainably and profitably. Finally, the future vision for M2M technologies is described, including prospective changes in relevant standards. This book is written by experts in the technology and business aspects of Machine-to-Machine and Internet of Things, and who have experience in implementing solutions.



Webinar on Software Testing; “Test Like Google”

Vector Software has set a series of dates from September – November 2014 on which it will present its “Using VectorCAST to Test like Google” Webinar. The company, a provider of software solutions for embedded software quality, has opened registration for the “Test like Google” webinar. This webinar will help attendees understand how preventing bugs decreases costs and eases schedule concerns, and offers insights into the process used by Google to identify bugs earlier in the product development lifecycle. The presentation will demonstrate how the VectorCAST solution’s automated testing capabilities can allow your organisation to achieve benefits similar

to what Google has achieved, using a commercial test tool. Vector Software is also announcing the Autumn 2014 Webinar Schedule. These free webinars are crafted to ensure that attendees are abreast of trends in software development and able to exploit the latest best practices. Each session is 30-45 minutes in length and will be archived on the Vector Software website.

For dates and times, click right; note the times are for EDT (US east coast): +6 hours for CET, +5 hours for GMT.





More than the sum of our parts.

parts.arrow.com

Search and compare millions of electronic components.

Get immediate access to Arrow's vast global inventory.

Design using the unique interactive reference design library.

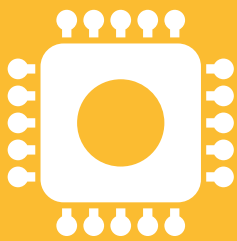

300M
Components.

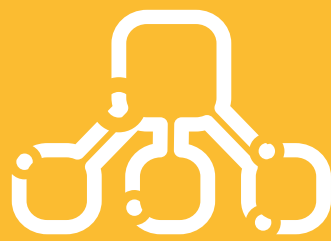

20,000
Reference
Designs.



One
Click.

Take a tour now at:

parts.arrow.com

V | Five Years Out

RSA encryption for embedded systems counters design cloning

Segger positions its emSecure as the first digital signature software package designed specifically for embedded systems. The emSecure module provides a selection of easy-to-use functions which allows the developer to easily add a digital signature to a product. The module includes an implementation of the RSA public-key cryptosystem and everything else which is needed for digitally signing data. emSecure will generate keys, as well as sign messages and verify signatures, based on asymmetric encryption (RSA) and discrete logarithms (DSA). emSecure can be used to authenticate firmware if the digital signature includes the unique ID of the microcontroller, forestalling cloning. It can also ensure secure firmware updates for any kind of embedded device. This is critical on devices

such as election machines, financial applications and other applications requiring secure licenses, serial numbers or sensitive data.

Based on RSA asymmetric encryption with two keys, it cannot be broken by reverse engineering. The source code has been designed and created, from the ground up, for embedded systems with no GPL or other open source licence. All parts of the package conform to the appropriate FIPS 186-4 specifications issued by NIST.



Complete article, here

Audi makes the leap to (partial) 48V supply

by Christoph Hammerschmidt

Car maker Audi has announced that it intends to partly equip its cars with an 48V electrical system. The split-voltage system gives automotive electricians and electronics designers the option to electrify additional units for the sake of overall efficiency. The company recently demonstrated prototypes of existing models A6 TDI and RS 5 TDI equipped with the 48V technology. Both vehicles featured an electrically driven air intake compressor which works independently of the engine rpm and thus offers "fundamental" improvements in terms of acceleration behaviour, the company says. Now a company spokesperson said the technology will enter series production within the "next two years." And this is the rationale of electrifying more and more units in the vehicle: Electrically-driven oil and coolant pumps, power steering and other dynamic subunits provide higher overall efficiency if they are driven by electric motors; and since the plethora of electric loads in cars increasingly drives the 12V power system to its limits, automotive electric system developers see the solution in an additional, separate 48V system. Such systems have been advocated by electric system designers for years; in 2011 top developers from Audi, BMW, Daimler, Porsche and Volk-

swagen have announced the introduction of such systems at an engineering congress in Ludwigsburg, Germany. With today's 12V systems, the high number of static loads in a car brings the alternator with a maximum output power of 3 kW to its limits, especially at low temperatures. The alternator power is typically not sufficient to supply innovative dynamic loads. The 48V subnetwork can supply such loads such as the above-mentioned rpm-independent compressor. In addition, it enables higher electrical efficiency as well as lower cable wire size and thus a lower weight of the cable harness. Audi regards this technology as an important building block of its strategy to further drive the electrification of in-car systems. The company says it already has developed a scalable modular platform concept that includes a

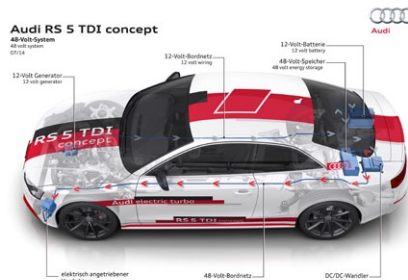

version that integrates the electric compressor. The top version of this platform utilises an 48V lithium-ion battery as energy source for phases when the engine is off. This battery works in conjunction with an energy-optimised alternator that provides an output of up to 10 kilowatts. This concept effectively turns the car into a Mild Hybrid.

Complete article, here

Single-chip, global coverage car radio receiver

Si4790x is an automotive receiver family that scales from economical, single-tuner designs to premium, multi-tuner car radio systems. The Silicon Labs IC family is designed to deliver optimum AM/FM and HD Radio/DAB/DMB digital radio performance for car radio systems, representing what the company terms a new benchmark for car radio reception performance while delivering the lowest system cost. The Si4790x family also provides flexibility and scalability for Tier 1 automotive infotainment suppliers and aftermarket car radio makers

worldwide. Silicon Labs claims a new level of performance for its AM/FM firmware running on a high-performance on-chip radio DSP, that, "sets a new bar for key automotive radio metrics such as sensitivity in weak signal environments, selectivity in the presence of blockers, and immunity to multipath fading and distortion." Many vehicles now feature multiple tuner ICs and antennae to deliver FM phase diversity reception, receive Radio Data System (RDS) data for info-navigation systems, and support digital

radio standards such as HD Radio - prevalent in the U.S. Market - and Digital Audio Broadcast (DAB), the leading European standard. To address today's global market, the Si4790x tuner family supports all worldwide broadcast radio bands including AM/FM, longwave (LW), shortwave (SW), NOAA



weather band, FM RDS decoding, and AM/FM HD Radio and DAB reception (Band-III and L-band). To help accelerate development of Si4790x-based systems, the Si4791-3T1A-EVB evaluation kit is available for \$1495.

Complete article, here

Off-the-shelf embedded USB host stack for FTDI's MCUs

The result of a collaboration with MCCI, FTDI Chip now has available TrueTask USB - an embedded USB host stack designed for use with FTDI Chip's FT900 product family. TrueTask USB is a high performance, production-ready embedded USB host stack supporting the FT900 series of application-focused microcontrollers (MCUs). Embedded product developers who select FT900 MCUs will have access to a solid USB platform capable of offering support a wide variety of USB peripherals - such as USB storage, portable media players, video/audio conferencing system peripherals, mobile phones, Wi-Fi dongles, etc. "The FT900 is a powerful, truly embedded MCU with an elegant architecture and rich connectivity offer-

ings," said Terry Moore, CEO of MCCI. "MCCI's USB host stack is field proven and comes with a very extensive class driver portfolio. By tightly integrating TrueTask USB with the FT900 MCU we were able to optimise performance and memory without compromising on quality and features"

"TrueTask USB from MCCI is well known throughout the embedded industry for high quality USB," said Fred Dart, CEO and Founder of FTDI Chip. "Having a pre-integrated, best in class USB stack is aligned with our product strategy for rapid go to market of our customers.

Complete article, here

MIPS Warrior core IP: 64-bit processing scales from mobile to high-end servers

Intellectual property company, and owner of the MIPS processor architecture Imagination Technologies has disclosed details of the MIPS I-class I6400 CPU family, which it positions as the first IP cores to combine a 64-bit architecture and hardware virtualisation with scalable performance through multi-threading, multi-core and multi-cluster coherent processing. This generation of 64-bit MIPS Warrior core offers an extended feature set and a performance/power/area mix that will enable a smaller core at the same performance, or a faster core in the same area. Despite the 64-bit/high end aspect, MIPS says that the core(s) will be of interest not only to those building the largest SoCs in 20-nm (and smaller) processes, but will be implemented in relatively mature processes such as 65nm.

Although this is nominally a "mid-range" core offering from MIPS, it raises the question of what constitutes mid-range for this class of IP. The company says that is defined by the size/power profile of the resulting cores, rather than outright processing power, of which, these cores can deliver a lot - especially if the application can use parallel processing. It is the balance of performance, power (Watts) and area, and the top clock frequency, that is the effective metric. In this announcement, Imagination Tech says it addresses the broadest range of markets of any of its IP; the I6400 series spans efficient, scalable 64-bit performance; simultaneous multi-threading; hardware virtualisation; advanced security; advanced power management; and a 128-bit SIMD architecture. The company anticipates applications across embedded, mobile, digital consumer, advanced communications, networking and storage.

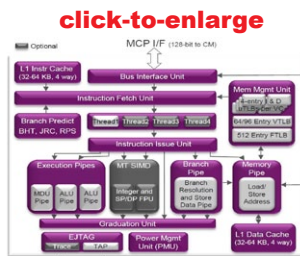

According to Tony King-Smith, Imagination's EVP marketing, "As the industry moves toward instruction set neutrality, customers can now choose a CPU based on its technical superiority. The I6400 is more efficient, flexible and scalable than the competition, and its feature set clearly lends itself to the needs of a wide range of next-generation applications including smartphones and tablets.

We know that unique features like multi-threading provide significant advantages for many applications."

Complete article, here

Understand WiFi-offload...
Join the FREE webinar

Register...

CONSUMER CONNECTIONS TOUGHEN UP FOR AUTOMOTIVE INFOTAINMENT

Today's connected cars are using Universal Serial Bus (USB) as a high-speed data interface. USB is already popular and proven in the consumer space, and will allow consumers to use many kinds of communication and infotainment devices in their vehicles.

Car buyers who may, just a few years ago, have been struck by the novelty of seeing a single USB port in a new vehicle are now increasingly likely to ask how many ports their latest purchase will have.

However, the electrical environment in a car differs significantly from that in a non-automotive scenario, in terms of Electro-Static Discharge (ESD) hazards and the large transients likely to be present. In addition, the 12V battery voltage represents a hazard to USB data lines. The vehicle's USB ports require effective protection against such hazards, in order to maintain signal integrity and ensure long-term reliability, which equates to an increased level of perceived quality, and fewer product returns or manufacturer recalls.

Connectivity is key

Leading car brands are increasingly looking to innovations in electronics to help create new features that win sales and build customer loyalty. Hand in hand with this trend, cars are becoming an integral part of today's digital consumer lifestyles. Today's car buyers want to bring not only their smartphones but also tablets, MP3 players, USB/SD storage and other devices into the vehicle, and connect these to the vehicle infotainment system to enjoy their content and access services while on the move.

To meet these demands, and also to support enhanced functionality such as telematics, car-to-car communication and ADAS (Advanced Driver Assistance Systems), the control unit for this functionality is evolving from a simple car radio to become a sophisticated computing platform. Powerful microcontrollers are emerging to fulfill these next-generation applications for the head unit. Such devices comprise sophisticated multicore processing, off-chip memory interfaces, and rich connectivity often including CAN, MOST, Ethernet, video camera inputs, and interfaces for wireless connections, as well as USB2.0 and/or USB3.0 ports. High-end microcontrollers may also provide the ability to output to multiple HD displays, while support for HDMI connections is expected to become widespread in the future.

Today, USB connectivity is vital to give vehicle users the flexibility to connect their own devices and storage and so access content and services as required. Increasingly, multiple USB ports are needed to allow front and backseat passengers, as well as the driver, to connect their own devices for various purposes, which may be different for the driver and passengers.

USB in the car

To provide satisfactory in-car USB connectivity, appropriate consideration must be given to regulating the USB power-sup-

ply voltage and current and protecting all of the USB data and power connections from various electrical hazards.

The USB power supply connection (Vbus) can be powered from either the HOST controller or from an external source (device). The Vbus voltage ranges from 4.75V to 5.25V, while the current ranges from 500 mA up to 2.1A, and more, for tablets and newer mobile devices. This can vary depending on the continuous and fast-charging requirements of individual equipment.

Among the electrical hazards likely to be encountered are ESD and transient events which may occur during manufacturing and assembly, or may be caused by vehicle occupants or other electrical circuits in the vehicle. The major documents discussing ESD and transient events as far as road vehicles are concerned are ISO 10605 (Road vehicles -- Test methods for electrical disturbances from electrostatic discharge) which describes ESD test methods and ISO 7637 (Road vehicles -- Electrical disturbances from conduction and coupling) for

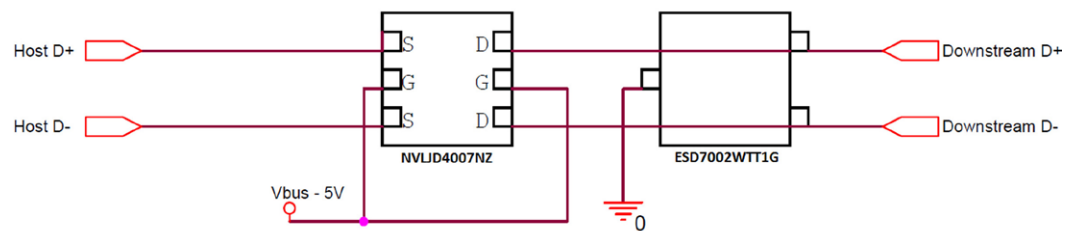

Figure 1 Discrete ESD transient and short-to-battery protection for USB2.0 port data lines using the ESD7002 and NVLJD4007 dual FETs

effects caused by other electronics in the vehicle. ISO 10605 is based on IEC 61000-4-2 Industry Standard, which specifies the various levels of ESD signal characteristics, but also includes additional vehicle-specific requirements. Further, OEM specific test requirements are usually also imposed.

In addition, all data-signal pairs in USB2.0 Full Speed/High Speed or multi-channel USB3.0 SuperSpeed interfaces, as well as Vbus and ground lines, require protection from short-to-battery (16 VDC) and short-to-ground faults.

A suitable protection solution must satisfy well-known constraints, such as low capacitive loading of the signal lines to minimise signal attenuation, and also respond quickly to surges and transients with low clamping voltage. In addition, small package sizes help to minimise demand for board-space while providing the ability to route the trace signals with minimal bending to maintain signal integrity.

Protection with flexibility

A two-stage protection solution can be envisioned, as shown in Figure 1. This solution comprises ESD protection diodes capable of surviving short-to-battery conditions, followed by dual FETs that prevent battery-level DC signals from damaging the protected circuits. An electronic fuse IC is used to protect Vbus connections against over-current situations. This implementation, using discrete components, allows devices to be selected that are optimised for protecting USB Vbus and high-speed data lines.





BY BONNIE BAKER

BAKER'S BEST



The inner workings of the three-op-amp INA

Instrumentation amplifiers (INA) can sometimes throw you a curve ball for even the easiest applications. One would use an INA to amplify a small differential signal to a usable voltage level in preparation for a following analogue-to-digital converter (ADC). The standard varieties of INAs come with two or three internal operational amplifiers (op amps). In this article, we look at the three-op amp variety (Figure 1).

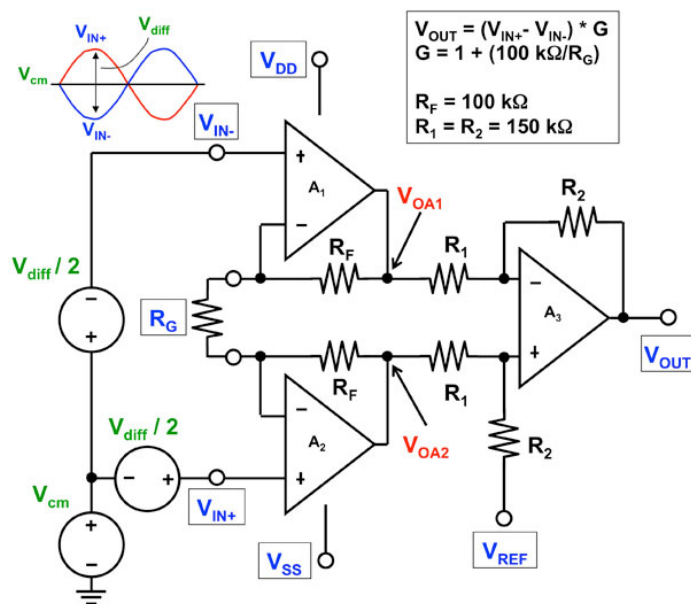

Figure 1 A three-op-amp instrumentation amplifier using the INA333.

The three op amps in Figure 1 are A₁, A₂ and A₃. Several variables influence the successful operation of this INA. These variables are V_{DD}, V_{SS}, V_{REF}, R_G, V_{CM}, and V_{DIFF}. This seems like a lot of balls to juggle, but the 'hidden' nodes that warrant special attention are the A₁ and A₂ output nodes: V_{OA1} and V_{OA2}. A₁ and A₂ in combination with R_G implement the gain of this INA, while A₃ converts the differential signal into a single-ended output.

So let's just jump in and see what happens. If a single power supply configuration is applied to the INA, for example, V_{DD} = 5V and V_{SS} = 0V, V_{CM} and V_{REF} are equal to (V_{DD} - V_{SS}) / 2. In our configuration R_G = 1.01 kΩ, which creates a gain of 100. In our circuit example, we keep V_{DD} = 5V, V_{SS} = 0V, and V_{CM} = 2.5V as above, but make the value of V_{REF} equal to ground, or 0V. This V_{REF} voltage conveniently reduces our chip count by removing the need for a voltage reference IC chip.

Let's try this circuit out. When I provide a differential +2 mV DC input signal between the V_{IN+} and V_{IN-} pins (V_{DIFF}), the output (V_{OUT}) becomes 0.2V, giving a gain of 100 V/V. But, when V_{DIFF} equals -2 mV, the output becomes 0.1V (gain = 50 V/V).

With this circuit configuration, let's apply V_{DIFF} input of +60 mV. At the bench, the output that appears on the output pin is 4.85V. This equates to a gain of ~81 V/V. The value of 4.85V is not high

enough to indicate that A₃ is overdriven. Is it true that this INA's gain is unstable?

Should I look for another INA in hopes of finding a stable one? Or better yet, figure out what is happening? In Figure 2, there is a generic list of critical internal relationships and formulae using the INA333. For a three-op-amp INA, these formulae will apply with the exception of the 100 mV and 75 mV values in the right column. These numeric values represent the limitations of the V_{OA1}, V_{OA2}, and V_{OUT} stages.

Critical Node Equations	Critical Node Limitations
$V_{IN+} = V_{cm} + \frac{V_{diff}}{2}$	Input limitations
$V_{IN-} = V_{cm} - \frac{V_{diff}}{2}$	$(V_{SS} + 100mV) \leq V_{IN+} \leq (V_{DD} - 100mV)$
$V_{OA1} = V_{cm} - \left(\frac{V_{diff}}{2}\right) \left(1 + \frac{100k}{R_G}\right)$	$(V_{SS} + 100mV) \leq V_{IN-} \leq (V_{DD} - 100mV)$
$V_{OA2} = V_{cm} + \left(\frac{V_{diff}}{2}\right) \left(1 + \frac{100k}{R_G}\right)$	V_{OA1} and V_{OA2} limitations
$V_{OUT} = V_{REF} + (V_{IN+} - V_{IN-}) \left(1 + \frac{100k}{R_G}\right)$	$(V_{SS} + 50mV) \leq V_{OA1} \leq (V_{DD} - 50mV)$
	$(V_{SS} + 50mV) \leq V_{OA2} \leq (V_{DD} - 50mV)$
	V_{OUT} limitations
	$(V_{SS} + 50mV) \leq V_{OUT} \leq (V_{DD} - 50mV)$

Figure 2 Critical internal node relationships and formulas for the INA333.

The critical node equations in the left column of Figure 2 describe values of five nodes. For our three-op-amp INA application, the values of these nodes are:

$$V_{IN+} = 2.5V + 60\text{ mV} / 2 = 2.53V$$
$$V_{IN-} = 2.5V - 60\text{ mV} / 2 = 2.47V$$

For future reference, we calculate the internal output voltages of A₁ and A₂. The input signals, V_{IN+} and V_{IN-}, go to the outputs of A₁ and A₂ provide these output voltages:

$$V_{OA1} = 2.5V - (60\text{ mV} / 2) (1 + 100k / 1.01k) = -0.5V$$
$$V_{OA2} = 2.5V + (60\text{ mV} / 2) (1 + 100k / 1.01k) = 5.5V$$

The output voltage of this INA circuit combines the reference voltage at the non-inverting input of A₃ and the amplified input signals (V_{IN+}, V_{IN-}).

$$V_{OUT} = 0V + (2.53V - 2.47V)(1 + 100k / 1.01k) = 6V$$

These equations provide a good, theoretical transfer function of the signals through this INA circuit. But, let's look at reality for a minute.

In the conclusion of this column (click right) Bonnie adds, "Be aware of the output swing limitations of these three internal amplifiers..." and details how to avoid inadvertently over-driving the internal op-amps of the device.



AUTOMOTIVE DESIGNS DEMAND 65V SYNCHRONOUS BUCK CONVERTERS WITH ULTRALOW I_Q

The rapid growth of very complex electronic systems in cars and commercial vehicles has created ever-higher demands on power management ICs. One of the most notable is a single power IC which must accommodate both single- and dual-cell lead acid battery configurations and their required transient behaviour.

“Globally, legislation continues to drive the development of next generation vehicle technology, offering further enhancements to emissions control and safety. Industry competition and consumer expectations are leading to higher levels of vehicle connectivity to the cloud and personal portable devices. As a result, demand for enabling semiconductor devices is expected to grow at a CAAGR (compound average annual growth rate) of 5% over the next seven years, with the total market worth over \$41 billion by 2021 compared to \$27.5 billion in 2013. The Strategy Analytics analysis also identifies that demand for microcontroller and power semiconductors will drive over 40% of revenues.” [Source: Strategy Analytics, May 2014]

Strategy Analytics [the analyst company] provides a very quantitative description of forecasting the growth of electronics content in cars and commercial vehicles, but more importantly the prevalent role that power ICs play in this growth. These new power IC designs must offer:

- 1) The highest efficiency possible to minimise thermal issues and optimise battery run-time.
- 2) Operation from a wide range of battery input voltages; both single-cell (automotive) and dual-cell (commercial vehicle) lead acid applications that can accommodate wide transient voltage swings.
- 3) Ultra-low quiescent current to enable always-on systems such as security, environmental control and infotainment systems to stay engaged without draining the vehicle’s battery when its engine (alternator) is not running.
- 4) Switching frequencies of 2 MHz or greater to keep the switching noise out of the AM radio band and to keep solution footprints very small.
- 5) Lowest EMI/EMC emission possible to reduce noise interference concerns within electronic systems.

The goal of the increased performance levels of power ICs is to design increasingly complex and numerous electronic systems found in cars to maximise comfort, safety and performance while simultaneously minimising harmful emissions. Specific applications fuelling the growth for electronic content in cars are found in every aspect of the vehicle. For example, new safety systems, including lane monitoring, adaptive safety control and automatic turning, dimming headlights and infotainment systems (telematics) continue to evolve and pack more functionality into that space and must support an ever growing number of cloud applications. Advanced engine management systems implement stop/start systems and electronics-laden transmissions and engine control. Drive train and chassis man-

agement is aimed at simultaneously improving performance, safety and comfort. A few years ago these systems were only found in “high-end” luxury cars, but now they are commonly found in automobiles from every manufacturer, accelerating automotive power IC growth at even a faster rate.

One of the key drivers for the growth of electronics systems is the adoption of many complex electronic systems improving the performance, comfort and safety of vehicles. But many of these systems are also designed to be used in a myriad of commercial vehicles, including trucks, buses, forklifts and so on. These applications generally use double batteries. But designers of many automotive systems would like the same design to service both single-cell automotive applications and dual-cell commercial vehicles, leading to a requirement for a single power IC that can accommodate both configurations.

By using two lead acid batteries in series, the nominal battery voltage increases to 24V and requires transient protection to 60V during load dump compared to a nominal voltage of 12V for a car and its load dump requirement of 36V. Conversely, single-cell automobile applications require power ICs to operate with inputs as low as 3.5V to accommodate low starting voltages found in cold-crank and stop-start scenarios. In dual-battery applications, this low input requirement is greatly relaxed and a minimum of only 7V (battery voltage) is required. The wide temporary voltage swing during cold-crank/stop-start and load dump for single-cell lead-acid batteries can be seen in Figure 1. Dual cell applications look similar, but the maximum voltage during load dump is generally 60V and the minimum during cold-crank/stop-start is 7V.

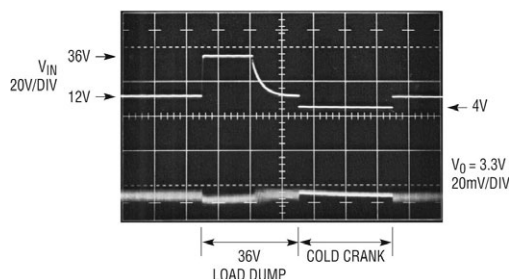

Figure 1 LT8620 with 36V load dump transient & 4V cold crank scenario

High Efficiency Operation

High efficiency operation of power management ICs in automotive applications is of primary importance for two main reasons. First, the more efficient the power conversion, the less energy is wasted in the form of heat. As heat is the enemy of the long-term reliability of any electronic system, it must be managed effectively which generally requires heat sinks for cooling; this adds complexity, size and cost to the solution. Secondly, any wasted electrical energy in hybrids or EVs will directly reduce their range. Until recently, high voltage monolithic power management ICs and high-efficiency synchronous rectification designs were mutually exclusive as the required IC processes could not support both goals. Historically, the highest efficiency solutions were high voltage controllers, which used external MOSFETs for their synchronous rectification. However, these configurations are relatively complex and bulky for applications under 15W when compared to a monolithic alternative. Fortunately, new power management ICs that can offer both high voltage (to 65V) and high efficiency and internal synchronous rectification can be found in the marketplace.





Analog Tips

LOCK-IN AMPLIFIER BY JASON BOUDREAU

The ADA2200 analogue-in, sampled analogue-out synchronous demodulator conditions signals in industrial, medical, and communications applications. All signal processing is performed in the analogue domain by sharing charge among capacitors, eliminating the effects of quantisation noise and rounding errors. The device includes a low-pass decimation filter, a programmable IIR filter, and a mixer, reducing ADC sample rates and downstream digital signal processing requirements. Single-ended and differential signal interfaces are possible on both input and output terminals, simplifying the connection to other components of the signal chain. The low power consumption and rail-to-rail operation is ideal for battery powered and low-voltage systems. The device can be programmed via its SPI-compatible serial port or it can automatically boot from EEPROM through its I²C interface. On-chip dividers derive the internal sampling clocks, allowing a frequency and phase selectable reference clock from a single clock input. In addition, the synchronisation output eases interfacing to other sampled systems, such as data converters and multiplexers.

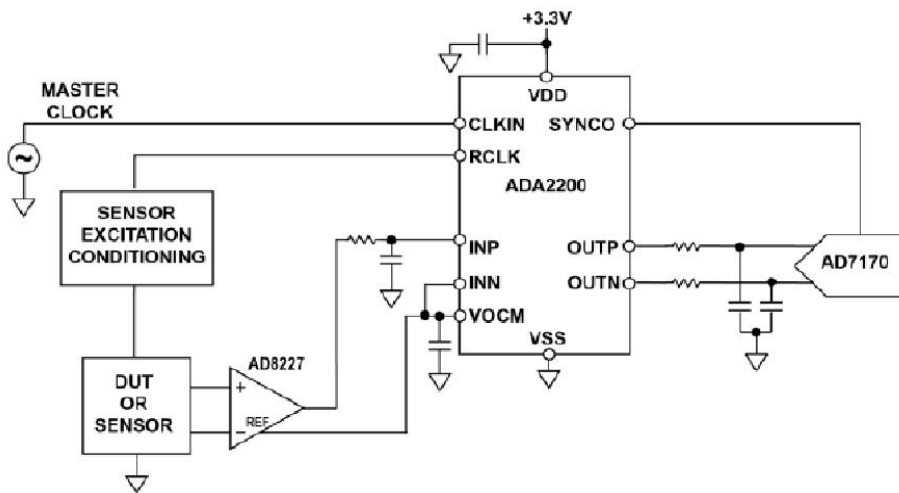

The figure shows the ADA2200 in a lock-in amplifier application. The 80-kHz master clock sets the input sample rate of the decimation filter, f_{s1} . The output sample rate is 10 kHz. In the default configuration, RCLK generates a 1.25-kHz excitation signal, which is also the centre frequency of the on-chip IIR filter. The RCLK output signal is buffered to provide a square wave or sine wave excitation signal to the sensor. The AD8227 low-noise instrumentation amplifier provides sufficient gain to amplify the sensor's output signal so that the noise floor is above the combined noise floor of the demodulator and the AD7170 ADC. In the default mode, the ADA2200 produces eight output samples for every cycle of the excitation (RCLK) signal. Four of the output sample values are unique, with the fourth value appearing on the output for five consecutive output sample periods. The output samples are digitally processed to optimise measurement accuracy, bandwidth, and throughput rate by taking the sum of eight samples to return a value. A moving average filter is used to lower the noise floor of the returned values. The length of the moving average filter is determined by the noise floor and settling time requirements.

Contact the author at; jason.boudreau@analog.com

swissbit®
INDUSTRIAL MEMORY SOLUTIONS



Designed for Automotive Applications

The most reliable Memory Card for read-intensive applications in wide temperature ranges

The S-40 Family:

- SD & Micro SD Card form factor
- 4 GB – 16 GB (MLC NAND FLASH)
- SD 3.0 (2.0), SDHC, Class 6
- Up to 24 MB/s data transfer rate
- Operating temperature range up to -40°C / +85°C
- Autonomous Data Care Management: fully independent monitoring of the stored data and prevention of Read Disturb effects and Data Retention issues
- Power fail and voltage drop safe
- Diagnose features
- Up to 96 bit ECC BCH code
- Fixed BOM & PCN process



More information at:
www.swissbit.com

AUTOMOTIVE · EMBEDDED · INDUSTRY
SECURITY · TELECOMMUNICATION

TRANSFORM SLOW SOFTWARE INTO FAST HARDWARE WITH VIVADO HLS

Learn how HLS enables speed-ups in your software: an exploration of some issues involved when accelerating software with high-level synthesis (Vivado HLS). This article provides an overview of the tasks and knowledge needed to perform such a transformation using the Zynq All Programmable SoC as the foundation for the design. (image; Xilinx)

Have you ever written some software that, despite your best coding efforts, didn't run as fast as desired? I have.

Have you thought, "If only there were an easy way to put some of the code into multiple custom processors or custom hardware that wasn't so expensive?" After all, your application is one of many, and custom hardware takes time and money to create. Or does it?

I began rethinking this proposition recently when I heard about the Xilinx high-level synthesis tool, Vivado HLS. In combination with the Zynq-7000 All Programmable SoC, which combines a dual-core ARM Cortex-A9 processor with an FPGA fabric, high-level synthesis opens up new possibilities in design. This class of tools creates highly tuned RTL from C, C++ or SystemC source code. Many purveyors of this technology exist, and the rate of adoption has been increasing in recent years.

So, how hard would it be to migrate some of that slow code into hardware, if indeed I could simply use Vivado HLS to do the more demanding computations? After all, I usually write

```
Matrix operand1(5,10), operand2(10,5), product(10,10);
int status;
status = matrix_op(MUL, operand1, operand2, product); // product = operand1 * operand2;
if (status != 0) cout << "ERROR: multiplication failed" << endl;
```

Figure 1. Example call to accelerator

my code in C++, and Vivado HLS uses C/C++ as an input. The presence of the ARM processor cores means I could run the bulk of my software in a conventional environment. In fact, Xilinx has even made available a software development kit (SDK) and PetaLinux for this purpose.

Architectural concerns

As I started to think about this transformation from a software perspective, I grew concerned about the software interface. After all, HLS creates hardware dedicated to processing hardware interfaces. I needed something easy to access, such as a coprocessor or hardware accelerator, to make the software

run faster. Also, I didn't want to write a new compiler. To make it easy to exchange data with the rest of the software, the interface needed to look like simple memory locations where we could place the inputs and later read back the results.

Then I made a discovery. Vivado HLS supports the idea of creating an AXI slave, with relatively little effort. This capability started me thinking that an accelerator might not be so diffi-

cult to create after all. Thus, I found myself coding up a simple example to explore the possibilities. I was pleasantly surprised with how it turned out.

Let's take a walk through the approach I took and consider the results.

For my example, I chose to model a set of simple matrix operations such as add and multiply. I didn't want it to be constrained to a fixed size, so I would have to provide both the input arrays and their respective sizes. An ideal interface would put all the values as simple arguments to a function, such as the code in Figure 1.

The interface to the hardware would need to have a simple way to map the function arguments to memory locations. Figure 2 (click right for next page) shows a memory layout to support this mapping. The registers would hold information about how matrices were laid out and what the desired operations would be. The command register would indicate which operation to do. This would allow me to combine several simple operations into one piece of hardware. The status register could simply be to know if the operation was in progress or had finished successfully. Ideally, the device would also support an interrupt. *continues...click right*

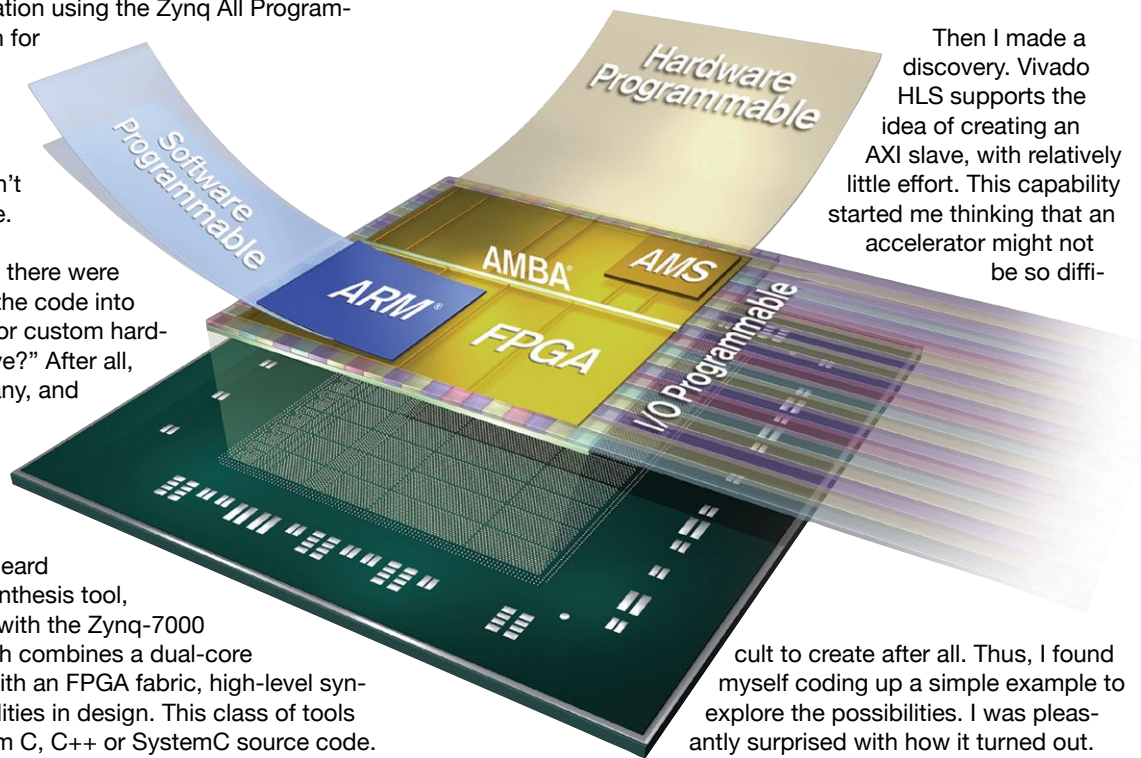

Keysight Basic Instruments

September-November 2014



New AC source/measurement capabilities
make sure your designs can handle
the uncertainties of real-world power.
SEE PAGE 4.

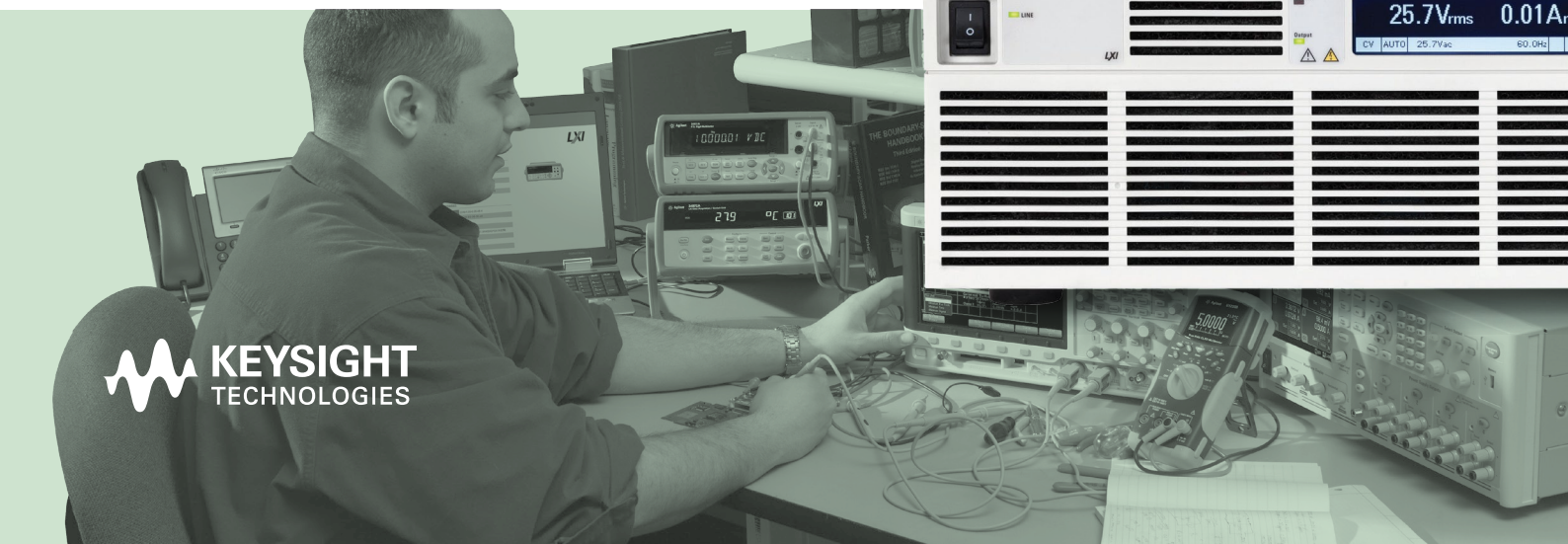

 **KEYSIGHT**
TECHNOLOGIES

Agilent's Electronic Measurement Group is now **Keysight Technologies**

Upgrade to Your Ultimate Scope

Get all licensed application software for the 2000, 3000, or 4000 X-Series scopes for one incredibly low price.

No promotion code needed.

Limited time offer, see page 6.

Futureproof your DMM with Truevolt

Get the 34461A plus GPIB interface and free BenchVUE connectivity software at the price of your 34401A DMM

Use promo code 5.972.

Offer Valid until December 31st 2014

Handheld Test Tools Extended Warranty Offer

Get 5 years of warranty for your U5855A TrueIR thermal imager, U1450A or U1460A series Insulation Resistance tester when registering it with us!

No promo code needed.

Offer valid until November 30th 2014

Expand Your TrueForm Memory

Get FREE memory upgrade for any new 33500B or 33600A series TrueForm waveform generator purchased by registering it with us.

No promo code needed.

Offer valid until March 31st 2015

Extend your DAQ

Get 5 years warranty for any new 34970A/34972A mainframe purchased when registering your new mainframe with us.

No promo code needed.

Offer valid until March 31st 2015



See our complete list of current promotions.

www.keysight.com/find/promotions



Get Greater Reliability—Standard

You've come to expect the highest quality from Keysight. We stand behind our products with a three-year warranty that's standard on all instruments, worldwide.

www.keysight.com/find/ThreeYearWarranty

Keysight & Our Distributor Network

RIGHT Instrument. RIGHT Expertise. Delivered RIGHT Now.

Keysight and our network of Keysight Authorized Distributors have teamed up to provide fast, easy access to the world's largest selection of off-the-shelf T&M instruments. It's the best of both worlds: Keysight's measurement expertise and product breadth combined with speed, convenience and same-day shipping from our distribution partners. It's never been easier to get the right instrument in the right hands, right away.



Quickly measure inrush current to verify power adapter design and production

If you design and manufacture power adapters, chargers, or similar devices, chances are you're looking for a fast, easy way to verify and test your devices. Checking your device's peak inrush current is an essential test and a common figure of merit for power supplies, for example. You need to make sure your adapters start up properly without blowing fuses, damaging switch contacts, or affecting the operation of other equipment connected to the same AC line. You may also need to measure input voltage, input current and input power at a variety of frequencies to make sure the power is within your specified range.

Inrush protection topologies

Power supplies use a variety of inrush limiting topologies, including these three common approaches:

- Input inductance in the transformer to limit peak inrush
- A negative temperature coefficient (NTC) resistor on the AC input line; when the resistor is cold, its high resistance limits inrush current to a manageable value, then after it warms up its resistance drops to a very low level and therefore doesn't dissipate much extra energy
- A resistor to limit the inrush current, with a relay which shorts out the resistor once the device is in operation to reduce power dissipation

With the second and third approaches, problems with that input resistor are among the more common causes of out-of-spec performance. If a resistor with an incorrect value is installed, or if the resistor malfunctions, the device may draw far more current than expected at startup.

Conventional test methods

Measuring inrush current used to require multiple pieces of equipment, such as a power supply, a digitizer and a shunt or a power supply, an oscilloscope and a current probe. These methods are not only more expensive but can be too complex and time-consuming when you're trying to execute high-speed testing on a manufacturing line.

Measuring inrush current with a single-box source/measure solution

The Keysight AC6800 Series basic AC power sources offer a quick and simple way to measure inrush current. With their built-in measurement capabilities, they provide everything you need to measure inrush current and a wide range of other power attributes (see Figure 1).

Maximum inrush current typically appears near 90 degrees in the AC cycle (see Figure 2), and the AC6800 sources lets you set the output to turn on at a specific phase to ensure verification under worst-case conditions.

The AC6800's current peak hold function captures the highest inrush current during the startup sequence (see Figure 3), and this value can be read by production techs from the front panel, displayed via the built-in Web browser over LAN or accessed programmatically in an automated test system.

The AC6800 Series offer stable, dependable power up to 270 V AC. Models from 500 VA to 4000 VA are available to meet basic AC source requirements at an affordable price.

141.4V _{rms}		5.00A _{rms}	
CV	HIGH	100.0Vac	100.0Vdc 500.0Hz
Lan			

See basic voltage and current measurement information.

141.4V _{rms}		5.00A _{rms}	
707.0W		707.1VA 1.00PF	
CV	HIGH	100.0Vac	100.0Vdc 500.0Hz
Lan			

See full details of all measurement information available.

100.0V AC	3.53A AC	8.53Apk	707.0W
100.0V DC	3.53A DC	8.53ApkH	707.1VA
141.4Vrms	5.00Arms	1.00PF	0.0VAR
CV	HIGH	100.0Vac	100.0Vdc 500.0Hz
Lan			

See voltage and current and power measurement information.

Figure 1. The AC6800 offers a wide range of built-in power measurements.

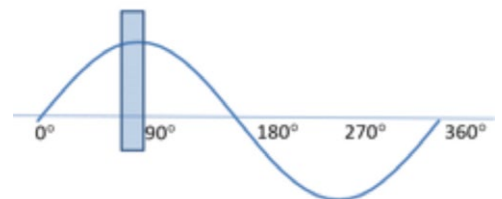

Figure 2: Maximum inrush current occurs around 90 degrees—at or just before the peak voltage of an AC cycle.

100.0V DC	3.53A DC	8.53ApkH	707.1VA
141.4Vrms	5.00Arms	1.00PF	0.0VAR
CV	HIGH	100.0Vac	100.0Vdc 500.0Hz
Lan			

Figure 3: The maximum inrush current is captured with the peak current hold function.

To learn more about the AC6800 and the advantage of one-box source/measure solutions, visit www.keysight.com/find/acsources

Find a Keysight distributor today at www.keysight.com/find/distributor

DC Power Supplies, Sources and BenchVue Software

HIGH VALUE: Solid performance and robust features help you achieve more on lower budgets

E3600 Series DC power supplies



- Output noise as low as 1mVp-p/0.2mVrms
- Tight 0.01% load and line regulation
- Fast load transient response time (<50 μ s)
- 30 to 200 W outputs
- BenchVue software compatible

U8000 Series DC power supplies



- Output sequencing (for U803x Series)
- Low output noise (as low as 1 mVrms) minimizes interference into your device-under-test (DUT)
- Fast load transient response time (<50 μ s) reduces test time and manufacturing cost
- Excellent 0.01% load and line regulation for steady output power levels
- Total power of 375 W at three outputs (for U803x series)

N5700 and N8700 Series system DC power supplies



- Basic, high-power, single-output power supplies
- 45 affordable models in compact 1 U (750 and 1500 W) and 2 U (3.3 and 5 kW) packages
- Up to 600 V or up to 400 A
- Programmability and built-in V & I measurements simplify test set ups

6030 Series basic autoranging DC supplies



- Autoranging to do the job of multiple power supplies
- 240 or 1200 W output, up to 500 V and up to 120 A
- Programmability and built-in V & I measurements simplify test setups

Quickly and accurately evaluate your DUTs with precision/low-noise sourcing and easy-to-use GUI

B2900A Series source measure units (SMUs)

- Superior graphical I-V Curve
- High sourcing and measurement resolution (6½ digit)
- Wide output range (210 V / 3 A DC / 10.5 A pulse)

B2960A Series low-noise power sources



- Ultra-low noise performance with the external low noise filter (10 μ Vrms)
- High sourcing resolution (6½ digit, 100 nV/10 fA)
- Innovative sourcing capability such as ARB and DC emulation

BenchVue software

Look for this icon throughout the catalog to identify compatible products.

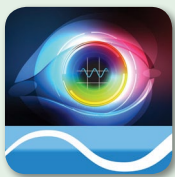

- Visualize multiple measurements simultaneously
- Easily capture data, screen shots and system state
- Recall past state of your bench to replicate results
- Measurement data export to Excel, Word and MATLAB with three clicks
- Fast access to manuals, drivers, firmware, FAQs, and videos
- Monitor and control your bench from mobile devices

AC Sources/Analyzers, DC Analyzers and Power Supplies

STABLE, RELIABLE AC POWER: Make sure your designs can handle unpredictable real-world power

AC6800 Series basic AC sources



- New basic AC source featuring stable and reliable power
- Four models: 500 to 4000 VA
- Dual range 135 / 270 Vrms, up to 120 A
- Intuitive user interface
- Access and control the source remotely using a standard Web browser

6800B Series performance AC sources/analyzers



- Complete AC power test solution
- Three models, up to 1750 VA (300 Vrms, up to 80 A)
- Extensive power measurement capabilities
- DC capability (DC only or DC + AC)
- Built-in arbitrary waveform generator to simulate many types of power waveforms

HIGH PERFORMANCE DC POWER: Anticipate new demands with high speed, versatility, and accuracy

N6700 modular power system and N6705B DC power analyzer



- N6700:** Ideal DC power supply solution for automated test systems
- Small 1U mainframe (400, 600, 1200 W); up to 4 modules
- More than 30 programmable DC power modules: basic, high performance, and precision (mA and μ A); available in 50, 100, 300, and 500 W



- N6705B:** Deep insight into DUT power consumption—without assembling a complex test system
- Integrated benchtop unit holds up to four N6700 series modules (600 W total)
- DMM, scope, arb, and data logger features
- New source/measure units and application-specific modules

BenchVue software compatible

6600 Series high-performance DC supplies



- Fast, low-noise outputs improve measurement accuracy and test throughput
- 40 to 6600 W, single output, up to 120 V, and up to 875 A
- Programmability and built-in V & I measurements simplify test setups

N3300 DC electronic load mainframe



- Stable and accurate: these loads are easy to integrate into your test system
- Automated command list execution reduces workload on system controller
- 1800 W mainframe accepts up to six 150 to 600 W modules for simultaneous testing
- Maximum inputs up to 240 V and 120 A

Handheld Instruments: Thermal Imager, Resistance Testers and Scopes

Quadrupled resolution, for a fraction of the cost!

PROMOTION

U5855A True/R thermal imager



NEW

- Get the clarity of 320 x 240 pixels at the cost of a 160 x 120 pixels detector with Fine Resolution capability
- For distant readings and inaccessible targets: digital zoom magnifies by up to 4x
- For close-up readings: accurately measure as close as 10 cm (3.9 in) to distinguish close-fit components
- In-camera monitoring and analysis capabilities
- Sensitivity (noise equivalent temperature difference): 0.07 °C
- Built-in tutorial, quick-access buttons, and custom settings to make the imager work the way you work
- 4 GB storage standard

Accomplish more in a day's work with remote testing plus report generation

PROMOTION

U1450A/U1460A Series insulation resistance testers



NEW

- Simplify routine and predictive maintenance with automated reporting and wireless testing
- Measure insulation resistance up to 260 GΩ, earth bond resistance, AC and DC volts, capacitance, continuity, and diode tests, plus current and temperature in the U1461A
- Standard test voltages 50, 100, 250, 500, and 100 V; adjustable 10 V up to 1.1 kV on selected models
- OLED displays on selected models offer crystal-clear readings
- Certified to IP 67, water proof up to 100 meters (328 ft), dust proof, drop proof up to 3 m (10 ft), CAT III 1000V and CAT IV 600 V

U1118A Wireless Combo Kit Key Features & Specifications



NEW

- Combines U1117A IR-to-Bluetooth® and U1115A Remote Logging Display
- View and log data from up to 4 handheld digital multimeters (DMMs) or clamp meters simultaneously and up to 100 meters*
- Download logged data to a PC via Bluetooth connection
- Micro USB external power port, Indoor and outdoor viewing mode, 60 000 points interval logging
- Compatible with ALL Agilent's U1200 Series handheld meters**

Big scope performance with a small scope price

1000 Series oscilloscopes

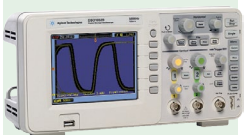

- 50 to 200 MHz, 2 and 4 channel DSO models with up to 20 kpts memory
- 5.7-inch color display offers powerful signal capture and display
- Up to 2 GSa/s sample rate
- 23 automatic measurements, sequential acquisition, mask testing and digital filters provide advanced measurement capabilities
- Accelerate your productivity with an 11-language user interface, USB connectivity, and a standard educator's kit

Handheld Instruments: DMM and Clamp Meters

Optimized to make precise and dependable measurements in the demanding conditions you face on the job.

U1230 Series DMMs



- Optimized for dark, noisy and even dangerous environments
- Built-in LED flashlight
- Flashing backlight as additional visual alert
- Vsense non-contact voltage detection

U1240 Series DMMs



- Low μ A and high M Ω ranges, harmonic ratio measurements, dual/differential temperature
- 10,000-count display
- 0.09% basic DCV accuracy

U1250 Series DMMs



- 0.025% basic DCV accuracy, accurate true-RMS AC measurements, and high-contrast OLED display (U1253B)
- 50,000-count dual display
- CAT III 1000 V and CAT IV 600 V safety rating

U1270 Series DMMs



- 30,000-count resolution and 0.05% basic DCV accuracy down to -40 °C
- Superior contrast with OLED display
- Low impedance mode, low pass filter, offset compensation
- Visual and audible continuity indications
- Dust and water resistant casing (certified to IP 54)

U1210 Series clamp meters



- Measure up to 1000 A and still see 10 mA
- Large 2-inch clamp opening
- CAT III 1000 V / CAT IV 600 V safety rating
- Includes full-featured DMM

Measurement Hint

Fine Resolution capability used in True/R thermal imager offers the capability to quadruple its effective thermal resolution and provides 1.5x better instantaneous Field of View (iFOV). This can be achieved through 3 processes, multi-frame acquisition, super-position and reconstruction. Since the cost of a thermal imager increases as resolution increases, the available budget often dictates the selection of the thermal imager solution. Now you can get Fine Resolution of 320 x 240 pixels and a more accurate temperature measurement at a fraction of the cost.

Find a Keysight distributor today at
www.keysight.com/find/distributor

Data Acquisition Units, Counters Spectrum Analyzers and Signal Generators

Modular flexibility and universal channels for a wide range of measurements with no external signal conditioning

PROMOTION

34970A/72A data acquisition switch units



- Low-cost, 3-slot unit with 6½ digit DMM and built-in signal conditioning
- Choose from 8 plug-in modules, up to 120 1-wire (60 2-wire) channels or 96 cross points
- BenchLink Data Logger software included, optional 34830A BenchLink Data Logger Pro
- GPIO and RS-232 connectivity (34970A) USB and LAN (LXI) connectivity (34972A) with built-in Web interface for easy control

High performance, multifunction counters cover the RF and microwave spectrum from 50 MHz to 46 GHz

53200 Series RF and universal frequency counters



- Frequency, frequency ratio, time interval, rise/fall time, phase, and much more
- Histograms, trending, data logging, and built-in math and statistical functions
- 53230A offers: 20 ps single-shot, burst microwave, and continuous gap-free measurements with time stamped edges
- Optional 6 or 15 GHz RF channel

Achieve more on a tight budget: Solid performance with robust measurement features

N9320B basic spectrum analyzer (BSA)



- Frequency range: 9 kHz to 3 GHz
- DANL: -148 dBm with pre-amp on
- RBW: 10 Hz to 1 MHz
- 3 GHz tracking generator
- PowerSuite: channel power, occupied bandwidth, and more
- AM/FM and ASK/FSK demodulation analysis
- Free remote control PC software
- BenchVue software compatible

N9322C basic spectrum analyzer (BSA)



- Frequency range: 9 kHz to 7 GHz
- DANL: -152 dBm typical, with preamp on
- RBW: 10 Hz to 3 MHz
- 7 GHz tracking generator, built-in VSWR bridge
- AM/FM, ASK/FSK demodulation
- Free remote control PC software
- BenchVue software compatible

5-in-1 RF analyzer: Spectrum analyzer, stimulus and response tester, spur and interference analyzer, ASK/FSK modulation analyzer, peak and average power meter

Professional performance and compact size for general purpose testing needs

N9310A RF signal generator



- 9 kHz to 3 GHz CW output, 20 Hz to 80 kHz low frequency (LF) output
- 127 to +13 dBm output level range (max +20 dBm settable)
- 95 dBc/Hz SSB phase noise
- Extensive analog modulation: AM, FM, phase, and pulse modulation
- Optional IQ modulator, 40 MHz bandwidth
- Up to ±0.1 ppm aging rate

Oscilloscopes and Applications

Breakthrough scope technology lets you see more, do more and get more for your money

InfiniiVision Oscilloscopes



- Up to 1,000,000 waveforms/sec update rate
- MegaZoom IV responsive, uncompromised smart memory
- Integrated—5 instruments available in one
- Fully upgradable—bandwidth, MSO, memory, serial analysis, built-in WaveGen function generator, or digital voltmeter
- BenchVue software compatible

2000 X-Series

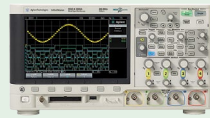

- 70 to 200 MHz bandwidth, up to 1 Mpts memory, DSO and MSO models
- 8.5-inch WVGA display offers 2x the viewing area and 5x the resolution of competitive scopes
- Standard 5-year warranty

3000 X-Series



- 100 MHz to 1 GHz bandwidth, up to 4 Mpts memory, DSO and MSO models
- 8.5-inch WVGA display is 50% larger and 3x the resolution of competitive scopes
- Segmented memory optional

4000 X-Series



- 200 MHz to 1.5 GHz bandwidth, 4 Mpts smart memory, DSO and MSO models
- 12.1-inch capacitive touch display is 40% larger than competitive scopes
- InfiniiScan Zone touch triggering—if you can see it, you can trigger on it
- Segmented memory standard

Upgrade to Your Ultimate Scope; get all listed options for the price of one option.

This limited time offer is valid for new Keysight X-series Oscilloscope purchases and also any Agilent X-series Oscilloscope purchased previously.

See also www.keysight.com/find/ultimatescope

PROMOTION

DSOX2APPBNDL 2000 X-Series	DSOX3APPBNDL 3000 X-Series	DSOX4APPBNDL 4000 X-Series
Included options:	Included options:	Included options:
Wavegen	Wavegen (incl ARB)	Wavegen (Dual ARB)
CAN/LIN	CAN/LIN	CAN (Symbolic)/LIN
RS232/UART	Flexray	Flexray
I2C/SPI	RS232/UART	USB 2.0 (low, full & high)
MASK test	I2C/SPI	USB 2.0 Signal Quality
Memory Upgrade	MIL-STD 1553/Arinc429	RS232/UART
Segmented Memory	I2S	I2C/SPI
DVM	Power	MIL-STD 1553/Arinc429
Education training signals	Advanced Math	I2S
	Video	FPGA Dynamic Probing
	MASK test	Power
	Memory upgrade	Video
	Segmented Memory	MASK test
	DVM	DVM
	Education training signals	Education training signals

Digital Multimeters and Waveform Generators

Benchtop DMMs

Exceptional performance and ease of use

 BenchVue software compatible



Model	Description	Features								Max reading rate at 4½ digits (rdgs/s)	Built-in PC interfaces
		Digits of resolution	DCV, DCI True RMS ACV/ACI	2- and 4-wire Ω	freq/period	diode/cont	cap.	temp.			
U3401A	Dual display. Elegantly simple and affordable DMMs with basic capabilities.	4½	•	•	•	•			3	None	
U3402A		5½							22		
U3606A	DMM with built-in 30 W power supply. Halves bench/rack space needed for two instruments.	5½	•	•					37	USB, GPIB	
34450A	Faster measurement speed, ultra-bright OLED with dual display, and basic statistical tools.	5½	•	•	•	•	•	•	190	USB, RS-232, optional GPIB	
34460A	Display DMM results in ways you never have before and measure with unquestioned Truevolt confidence. 100% drop-in replacement.	6½	•	•	•	•	•	•	300	USB, optional GPIB and LAN	
34461A									1,000	USB, LAN, optional GPIB	
34401A	Industry standard for accuracy, speed, measurement ease and versatility.	6½	•	•	•	•	•	•	1,000	GPIB	
34410A	Dual display. Highest throughput of benchtop DMMs, best choice for system use.	6½	•	•	•	•	•	•	10,000	USB, GPIB, LAN	
34411A									50,000		

PROMO

Waveform Generators

General purpose and precision models with exclusive Trueform technology

- Trueform technology generates signals with the lowest jitter and harmonic distortion
- Generate Trueform point-by-point arbitrary waveforms with less jitter, more fidelity and greater resolution.

 BenchVue software compatible



Model	Description	Channels	Frequency range	Pulse	Arbitrary waveforms					Modulation			
					Std/Opt arb	# bits	Sample rate	Standard memory	Optional memory	AM/FM	FSK	PWM	
33210A	General-purpose function and arbitrary waveform generators.	1	10 MHz	5 MHz	Opt	14	50 MSa/s	8 K	-	•		•	
33220A			20 MHz	5 MHz	Std	14	50 MSa/s	64 K	-	•	•	•	
33250A			80 MHz	50 MHz	Std	12	200 MSa/s	64 K	-	•	•		
33509B/ 33511B	Exclusive Trueform waveform technology with <40 ps jitter and <0.04% THD.	1	20 MHz	20 MHz	Opt/Std	16	160 MSa/s	1 M	16 M	•	•	•	
33510B/ 33512B			2	20 MHz	20 MHz	Opt/Std	16	160 MSa/s	1 M	16 M	•	•	•
33519B/ 33521B			1	30 MHz	30 MHz	Opt/Std	16	250 MSa/s	1 M	16 M	•	•	•
33520B/ 33522B			2	30 MHz	30 MHz	Opt/Std	16	250 MSa/s	1 M	16 M	•	•	•
33611A	Exclusive Trueform waveform technology at higher frequency ranges with <1 ps jitter <0.03% THD.	1	80 MHz	80 MHz	Std	14	660 MSa/s	4 M	64 M	•	•	•	
33612A			2	80 MHz	80 MHz	Std	14	660 MSa/s	4 M	64 M	•	•	•
33621A			1	120 MHz	100 MHz	Std	14	1 GSa/s	4 M	64 M	•	•	•
33622A			2	120 MHz	100 MHz	Std	14	1 GSa/s	4 M	64 M	•	•	•

PROMOTION

Find a Keysight distributor today at www.keysight.com/find/distributor

AC6800 and 6800B Series Basic and Performance AC Power Sources

Engineer dependability into your designs with stable, reliable AC power



6800B Series

AC6800 Series

Test your designs with confidence, knowing that your products will perform as designed—even if they encounter fluctuating voltages from the AC power grid, extreme inrush currents, or transient spikes. Agilent's two families of AC power sources provide the capabilities you need for thorough AC testing, from basic power to more sophisticated source and measurement needs.

Both families also produce DC power, either alone or as a DC offset to an AC waveform. All models are backed with global support and the longest standard warranty in the industry.

See page 4



Bluetooth and the Bluetooth logos are trademarks owned by Bluetooth SIG, Inc., U.S.A. and licensed to Keysight Technologies, Inc.

Technical data and pricing subject to change without notice.

© Keysight Technologies 2014
Published in USA, September 1, 2014
5991-4831EEE
www.keysight.com

WHAT ABOUT DC POWER INTEGRITY? - PART 2

It's getting really difficult to plan and design a good power network on the PCB. Whether we like it or not, Power Integrity is a challenge that all PCB designers and engineers have to address.

Part 1 of this article outlined the basic principles of ensuring power integrity (PI) on a PCB; at symptoms that reveal your board may have a PI problem; and at extracting some key figures from active device data sheets; Part 1 is [here](#).

Monitoring tools for embedded systems

One useful function offered by modern embedded tools is the ability to monitor power consumption in concert with debugging code. Various means of measuring power are provided.

For example, the STM32429IG-EVAL board from ST Micro, which uses a variant of the ARM processor mentioned in Part 1 of this article, is designed with a jumper in place for the VDD rail to the CPU. The intent is that while you are developing and debugging source code you can be measuring the current being supplied to the CPU:

1. Set a breakpoint at the beginning and end of the code routine of interest.
2. Enable the oscilloscope trigger on the current measurement probe on JP2.
3. Step into the routine, capturing the current waveform on the 'scope.
4. Repeat for all routines of interest, taking note of the current requirements.

This way, you can get a clear picture of how the source code is affecting power consumption, and even decide how to modify code to optimise or limit power usage.

Similar tools are available for monitoring FPGA development flows. Figure 4 shows the power monitoring capability of the NanoBoard FPGA development board. In this example I am running the C-to-Hardware reference design that spins a graphical cube in 3D. I can switch between processing the matrices for transformation in software and FPGA hardware, and compare the power consumption based on how the job is done. Similar tools can be found with FPGA vendor development boards as well.

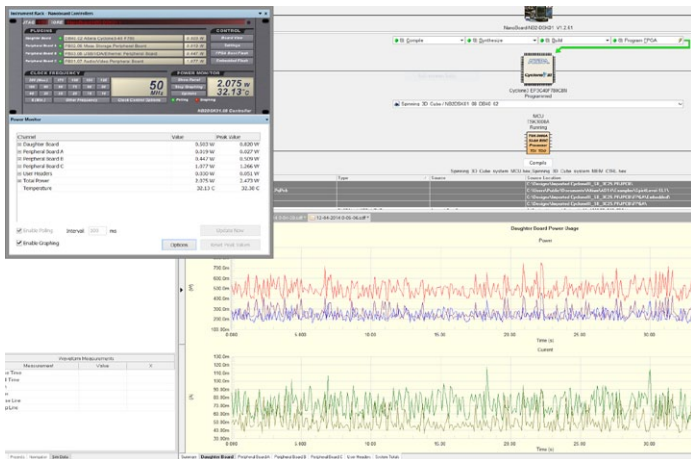

Figure 4 Monitoring power consumption during FPGA/Software debug of a System on Chip design.

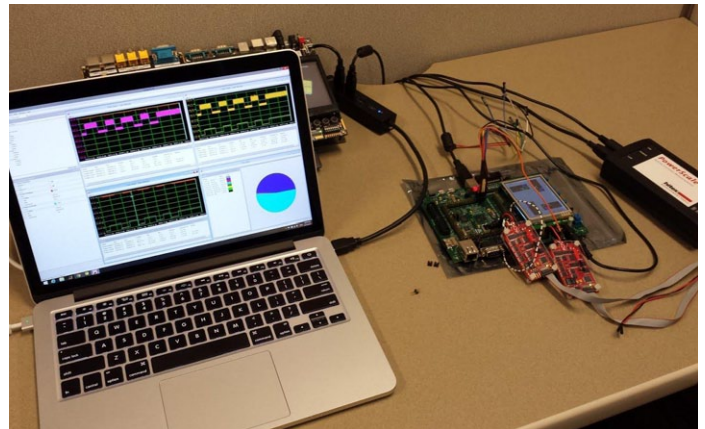

Figure 5 Using high-speed current probes with the development board.

Working with DSO or PC-based instruments along with the embedded debug tools even give you an edge in developing lower power code. Figure 5 shows this in action with “Power-Scale” (from Hitex, which works alongside Altium’s TASKING C/C++ development tools).

In this case it's easy to measure peak and average currents required by your source code over the software execution lifecycle. But what can you do to ensure that your custom PCB design can cope?

So what's it to do with DC Power Integrity?

Modern designs are complex, and with limited space to design the power network on the PCB, and with ever shrinking device packages, it's getting hard to use the old brute force “plenty of copper” approach to providing power to these devices. Knowing about these techniques will be key in using a multi-pronged approach to solving power integrity bottlenecks at the PCB design level also.

A PCB fuse trick?

Before I dive in though let me share a little story. When I was a wet-behind-the-ears college student, I had a part-time job doing PCB design and assembly at a “ma and pa” electronics company in my hometown. They were really cool people, and I learned a great deal about PCB design and hand prototyping, design for assembly, and testing from the proprietor. I was impressionable in those days, and one thing he impressed me with at the time was how he used to design fuses into his PCBs with thin trace segments, and a component land pattern for a real fuse should the PCB trace need “replacing”. The fuse was apparently rated at 2A, and was a 10 mil (0.010 in./0.25 mm) width in standard 1oz. copper. I wondered if he had some magic formula or if he had empirically chosen the width. He wouldn't tell me...

In the continuation of this article, Benjamin Jordan goes on to discuss how polygon “necks” (narrow trace points) can be points of stress in the PCB power network and delves into the physics of current flow through the PCB trace cross-section – click right.



Teardown: 1966 Programmable scientific calculator

I've taken a screwdriver to my rare and wonderful Wang LOCI-2 calculator...

This machine's design seems to be from 1965, though I estimate mine was made in 1967, the same year Young-Me trundled off on a barely-remembered trip to Expo '67 in Montréal. It's a remarkable design achievement. Using over 1,000 transistors (and not a single IC), it manages to implement log and antilog functions, and in turn leverages those to perform squares and square roots, multiplication, division, and more. It also has a 16-register core memory, a 10-digit Nixie display, and is programmable!

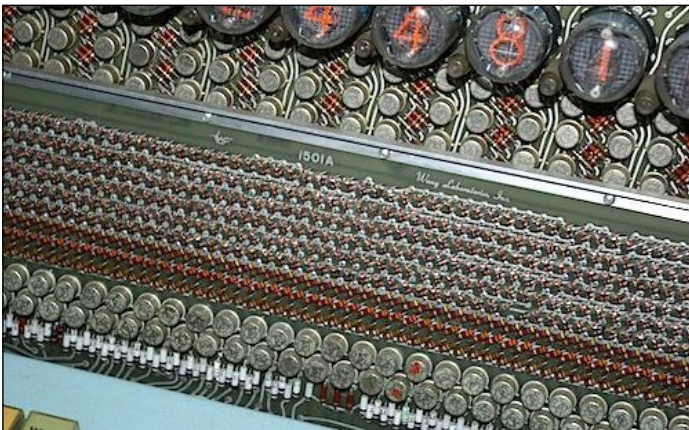

The top-view Nixie displays.

What memory technology is used for program storage, you ask? Paper! Yes – good old paper punchcards, except the card reader doesn't pull a card through and store its contents in RAM. The card itself is the RAM (well, ROM), and the card reader has a contact at every possible hole position. The card is read directly as the program executes. If you're wondering, the original selling price was about \$3,000 – automobile range then!

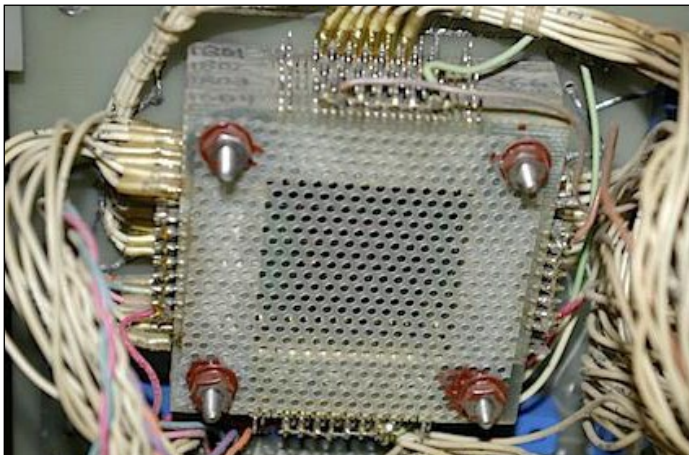

The four-plane core memory module. Note the twisted pairs.



The card-cage. Each card is unique.

Apart from a general cleanup, I haven't done any restoration work yet. The machine lights up and responds to keypresses, but doesn't work too well. Clearly, it needs to get onto the lab bench, and the good scope needs to be fired up. Maybe all it will need is a new power supply filter capacitor.

The PCBs themselves are interesting: double-sided, yet no component-side pads unless they're needed as a via.

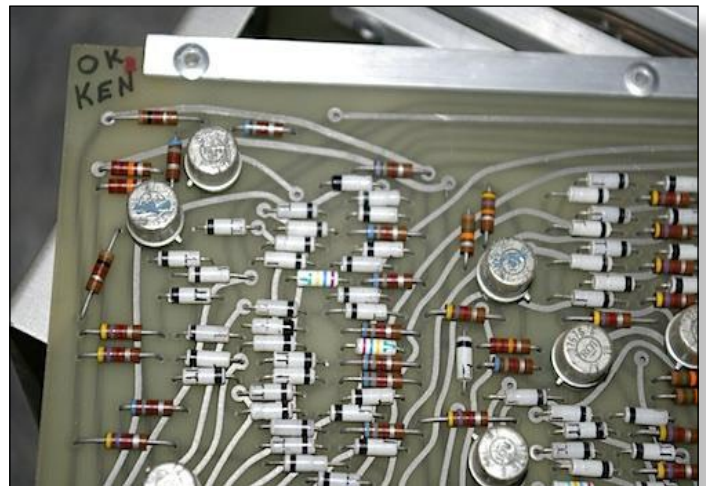

The "Ken" seal of approval.

Further pictures of the construction of this vintage calculator are in the online version of this article, click right.



QUANTIFYING SERIAL LINK PERFORMANCE; SATA 6G SIGNAL QUALITY VS SSD BENCHMARKS

SSD benchmarks are used to determine the data transfer rates of hard drives. However, it is all too often forgotten that the data transfer between controller and hard drive plays as important a role as the properties of the hard drive itself.

The SATA specification defines a data rate of 6 Gbit/sec. 8b/10b encoding of the transmitted data leads to a 20% overhead that is not used for user data. The protocol also requires extra bandwidth to compress the data into the FIS (Frame Information Structure). The underlying assumption is that all data is transmitted without errors. To detect individual errors and to verify the transmission, the SATA specification defines a CRC (Cyclic Redundancy Check) error detection code. While CRC is very efficient, it can only detect errors, it cannot repair them. So, if an error occurs, the data transmission has to be restarted.

The theory

To prevent the data transmission from needing to restart, the specification defines clear attributes for the signals. For instance, the signal frequency on the circuit board and the connector is specified at 3 GHz (6 Gbit/sec). At these frequencies, PCB routing must follow specific rules. But, it is no longer enough to simply follow high speed routing rules. Various tricks are applied on the chips to optimise the transfer and the behaviour of the controller modules also needs to be aligned with the routing. On the driver side, pre-emphasis - a kind of signal pre-distortion - is used to compensate for the characteristics of the transmission line from transmitter to receiver. A typical SATA transmission line consists of the PCB routing, at least two connectors and a cable. This line forms an RC combination that acts primarily as a low-pass filter. However, the exact properties of the filter vary from system to system. By adjusting the strength of driver and pre-emphasis, it is possible to align chips and system. The driver strength also influences the absolute signal strength, while pre-emphasis adjusts the strength for non-transition bits, i.e. bits that do not follow a transition.

PCIe Gen3 provides a complex algorithm that lets the transmitter and receiver negotiate the best settings. The SATA specification is not as flexible, so it is up to the chip makers to decide on the level of flexibility to incorporate, and up to the board manufacturers to take advantage of this flexibility to optimise the system. Today, it is no longer enough to pre-distort the signals simply on the driver side; the signals also need to be post-processed at the receiver side using equalisation. Again, there are different settings for an optimum alignment of systems. Ideally, the device (SSD) and host (motherboard) manufacturers each handle this by compensating for the characteristics of their boards. The properties of the connecting cables are also clearly specified, so that it is possible to build an optimised system.

Hardware manufacturers use so-called compliance tests to verify signal quality. For this, the controller is put into test mode and drives clearly defined test patterns which are evaluated with an oscilloscope. Since the introduction of the third interface generations (USB, PCIe and SATA) compliance needs to be tested both on the side of the transmitter and the receiver. In the latter case, the worst permissible signal is sent to the

receiver which rates the signal and sends the same information back (loop back mode). The information is then evaluated by a bit error rate tester (BERT) and compared with the transmitted data. The hardware required for this rapidly reaches the value of a reasonably-sized family house.

If the expense is spared, the systems usually work but fail to achieve the full performance that one would expect. The error detection of the SATA interface is very effective, so it is rare for an error to go undetected. However, the repetitions require bandwidth and if there are too many of them, the usable bandwidth can be significantly reduced.

Measuring the practical impact

To show the effects, a congatec test system with an Intel Series 7 controller was used to determine the write bandwidth depending on the transmitter setting. To ensure comparability with tests published by the trade magazine c't an IOMeter and the same settings were used. The test object was a Samsung SSD 840 Pro. In addition to the high transmission rates of the SSD, a reason for this choice was that Samsung uses SMART so that the interface CRC count for 0xC7 is also reported. Alternatively, this information would also be available via the PCH registers or the Windows Event Viewer. While IOMeter also gives an error count, this only kicks in when the controller loses the connection to the hard drive.

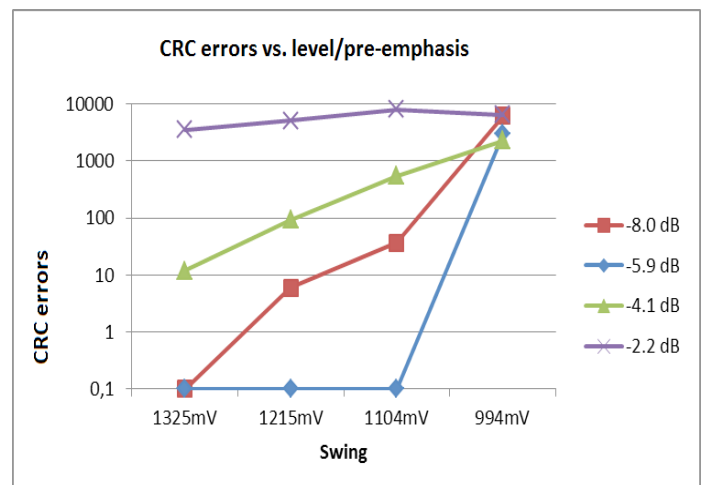

Figure 1. CRC error vs transmitter settings

For the tests, the settings of the output driver were modified as follows: The signal strength was changed from 994 mV to 1325 mV and the pre-emphasis set to vary between -2.2 dB and -8 dB. The same tests can be done by modifying the receiver settings (receiver equalisation), but in this case the changes cannot be graphically represented.

Click right to read the continuation of this article, which notes that the first errors are visible long before the transmission rate degrades which is 'not acceptable' - detail of the transmit- and receive-side tests follows.



THIS ARTICLE ORIGINALLY APPEARED IN **LINEAR AUDIO**, A BOOK-FORMAT AUDIO MAGAZINE PUBLISHED HALF-YEARLY BY JAN DIDDEN.

THE G WORD: HOW TO GET YOUR AUDIO OFF THE GROUND (PART 2)

Balance

The ideal differential input would be a transformer. By "ideal" I mean in terms of how well it would manage to look like a voltmeter with just two connections on it. Even if there were hundreds of volts between the chassis of the source and the receiver, this would go completely unnoticed. Other than that, a balanced connection will look more like Figure 7.

V_{cm} symbolises any voltage between the two chassis, however it arose. If the input had been a transformer, no current would flow through the two signal wires, but transformerless inputs necessarily have some input network, if only to provide a path for base currents. The task is to minimise the impact this current will have on the recovered audio signal.

Let's assume the source is putting out 0V and redraw the circuit as a Wheatstone bridge as in Figure 8. Any signal seen between the inputs of the difference amplifier is unwanted.

It's clear that we don't need a transformer. We can allow current to flow through the signal wires so long as R_{oh}/R_{ih} = R_{ol}/R_{il}. If the input resistors are well-matched and so are the output resistors, no amount of common-mode voltage will get converted into an output signal.

When a Wheatstone bridge is exactly nulled, the term we use is that the bridge is balanced. That is where the word "balanced connection" comes from. It has nothing at all to do with one voltage going up while the other goes down, but with divider ratios being equal. Don't think uppy-downy. Think equilibrium. Zen. Ooohmmmm...

The ratio between the error voltage and the common-mode voltage is the common-mode conversion ratio. The smaller it is, the better. It's more common to quote this number in relation with the wanted signal, expressed in decibels. This ratio is called the Common-Mode Rejection Ratio (CMRR):

$$CMRR = -20 \cdot \log \left(\left| \frac{V_{err}/V_{cm}}{V_{dm}/V_{out}} \right| \right)$$

Let's explore for a second what happens if the output resistances are matched i.e., R_{oh} = R_{ol} = R_o but the input resistances aren't, say R_{il} = R_i and R_{ih} = R_i + Δr_i:

$$\left| \frac{V_{err}/V_{cm}}{V_{dm}/V_{out}} \right| \approx \frac{\Delta R_i \cdot R_o}{R_i \cdot (R_o + R_i)} \approx \frac{\Delta R_i \cdot R_o}{R_i^2}$$

The sensitivity to an imbalance in the input resistance increases with output resistance. It pays to minimise output resistance. It also decreases, quite rapidly, with increasing input resistance. So that seems a good idea too.

Secondly, let's explore the impact of an imbalance in the output resistances:

$$\left| \frac{V_{err}/V_{cm}}{V_{dm}/V_{out}} \right| \approx \frac{\Delta R_o}{R_i + R_o} \approx \frac{\Delta R_o}{R_i}$$

This is fairly important. If your input network consists of two resistors to some local reference, making those resistors as large as you can is going to make a lot of difference. And when you measure CMRR, do so with an imbalance of several ohms on the source side because that test will tell you a lot more about the real-world ability of an input to reject CMRR than a bench test with the inputs perfectly shorted together.

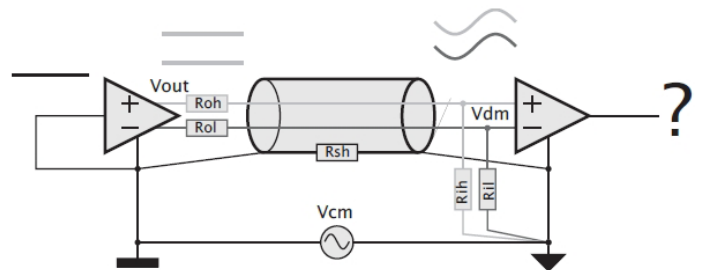

Figure 7 A typical transformerless balanced connection.

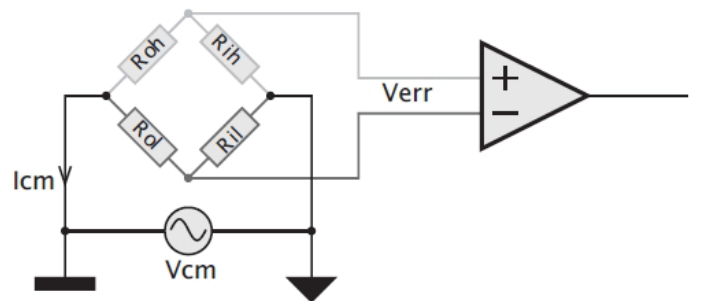

Figure 8 Input/output resistances seen as a Wheatstone bridge.

$$\frac{V_{err}}{V_{cm}} = \frac{R_{ih}}{R_{oh} + R_{ih}} - \frac{R_{il}}{R_{ol} + R_{il}}$$

$$\frac{V_{dm}}{V_{out}} = \frac{R_i}{R_o + R_i}$$

In the continuation of this article, Bruno Putzeys looks at "acting locally" - considering signal effects within the confines of an amplifier enclosure. [Click right.](#)

In part 1 of this article, the author explored the issues of the conventional approach to a ground-based layout for audio circuitry, and the problems of "Gnd-think" - [catch up with Part 1 here.](#)



designideas

READERS SOLVE DESIGN PROBLEMS

Add phases to simple RC oscillator

Einar Abell



This Design Idea demonstrates a simple way to generate a multiphase clock signal, the frequency of which can be varied with minimal change in phase shift(s).

The phase shift of the second output can be tuned from near zero to 180° without affecting the frequency. The basic circuit uses a minimum of parts: one capacitor, two resistors, plus two Schmitt triggers.

Frequency is a function of C1 and the sum of R1 and R2. U2 provides the phase shifted output – which leads the master output of U1 – via the tap on variable resistor R1. When the output of U1 is high and C1 is charging up, the voltage at the input to U2 will be higher than the voltage at the input to U1; therefore U2 will change state before U1, creating a phase lead. When U1's output is low, the input to U2 will be lower than U1's input, and it will again trigger ahead of U1. The closer the wiper of R1 is to R2, the greater the phase lead.

With CMOS Schmitt triggers, the input thresholds are not perfectly symmetrical relative to the output, and the two phase shifts will not be equal. This asymmetry is particularly noticeable with small phase leads.

R1 controls the phase shift, and R2 can be

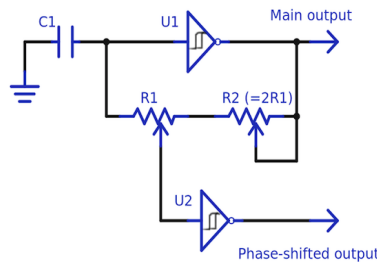

Figure 1. Two-phase oscillator with adjustable frequency & phase-shift

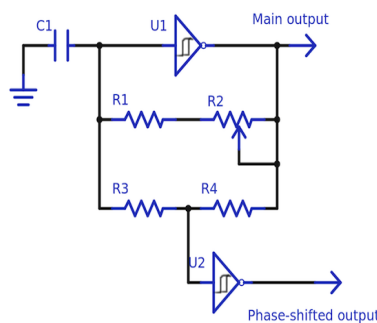

Figure 2. Greater independence of frequency & phase

varied to trim the frequency (since this will alter phase, you should trim frequency, then phase). I show variable resistors in the schematic, but you can make one or both fixed; or, make R1 and R2 a single variable resistor, giving no frequency adjustment and a restricted adjustment range. Slight differences in the threshold voltages between U1 and U2 prevent setting the phase shift to zero or very close to it.

Figure 2 shows a way to vary frequency with minimal change in phase. In this circuit, R1 and R2 control frequency and R3 and R4 set the phase. The sum of R3 and R4 should be equal or greater than the sum of R1 and R2. You can achieve an adjustment range of a decade or so with minimal change in phase. Trying for more doesn't work too well because the input capacitance of U2 causes a phase lag, and this becomes significant at higher frequencies. To keep things simple, I show only a two phase circuit, but more phases are possible by adding more resistors or pots (a classic three-phase oscillator could be created from Figure 2 if R3 was split into equal halves and the signal from this midpoint was inverted relative to the other two phases). This idea is not limited to CMOS Schmitt triggers; it can also be used with oscillators made from comparators or a 556.

Improve efficiency of low-cost switcher

Peter Demchenko



Low-current switching regulator ICs often use a Darlington as the output switch. The power conversion efficiency in this case can be improved with the help of only two cheap components.

To make this possible, the chip should have a separate pin for the collector of the driver transistor Q1 (Figure 1). At startup, D1 forms a path for the collector current of Q1. Later, D1 and C1 comprise a current-additive rectifier which enhances the collector voltage and current of Q1, hence reducing voltage drop on the closed switch Q2.

Another advantage is the ability to work with lower input voltages. The circuit provides wider input range due to increased voltage on the collector of the driver.

The value of C1 depends on switching frequency. Values in the range of 47 nF to 150 nF are typical. Resistor R1 may be needed to avoid hard saturation of Q2, or to limit the collector current of Q1, depending on the input voltage and the parameters of Q1. The resistor can be omitted in most cases (i.e., R1 = 0Ω).

An example of this DI concept with the popular MC33063/MC34063 in a buck configuration is shown in Figure 2.

When $V_{in}=12V$, the above configuration, loaded with 24Ω, has an efficiency of 85%, and the minimum input voltage is 7.5V. Under the same conditions, the standard circuit, without C1 and D1, and with pins 1 and 8 connected, has an efficiency of 78%, and minimum input voltage of 8.2V.

The same approach can be used with an inverting converter configuration.

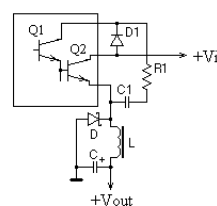

Figure 1

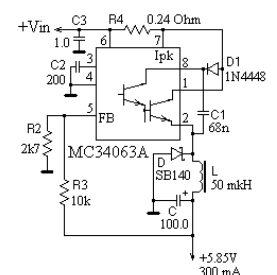

Figure 2

Avago Tech Note: Isolated current sensing with Σ - Δ optoisolators Avago Technologies



In Industrial motor or servo control applications, accurate current measurement is a critical as part of the control loop. Not only does the current measurement need to be as accurate as possible, it also needs to be safe and reliable. Industrial motor or servo control systems usually contain high voltages and in fault events such as over-current or short circuits, these conditions need to be detected and rectified quickly to prevent catastrophic systems failures or in the worst case, human injury. Not only does the use of optocouplers help to provide isolation in breaking ground loops, rejecting common mode noise and transients, it provides the necessary insulation to meet the required safety standards and regulatory requirements.

Optically isolated modulator architecture

The inputs of an isolated modulator used in current measurements are usually connected to a small shunt resistor, which converts the current passing through it to a small voltage, usually about ± 200 mV, so as to limit the power dissipation in the shunt resistor. The sigma delta modulator then oversamples the analogue input signal into a single high speed bitstream before transmission across the optical isolation barrier. The modulator data received on the isolated side is then sent to a processor for further processing. A Sinc3 decimation filter can then be easily implemented on an FPGA or microprocessor to recover the desired signal. The decimation filter averages or decimates the high speed oversampled bitstream to a lower rate by a factor, commonly known as decimation ratio. Figure 1 shows the block diagram of an isolated sigma delta acquisition system.

There are a couple of advantages with such approach. Firstly, an isolation barrier can be easily placed on a single channel immediately after the modulator output. Secondly, any errors in the received bitstream that could be caused by common mode transients would have been averaged out by the decimation filter. The result is a very robust isolation scheme which provides good common mode rejection between primary and secondary or transient immunity in highly noisy environments such as motor control. Being optical in nature, the device is also immune to

magnetic interference that may trouble conventional Hall Effect sensors. Figure 2 shows a block diagram of the Avago ACPL-798J externally clocked optically isolated Sigma-Delta Modulator with LVDS interface.

The LVDS interface further improves the connection between the sensor and the processor as compared to the usual single ended LVTTTL interface, allowing system designers to have a robust interface. The ACPL-798J also offers good gain accuracy of $\pm 1\%$ and 75 dB of Signal to noise ratio equivalent to 12 bits effective number of bits (ENOB).

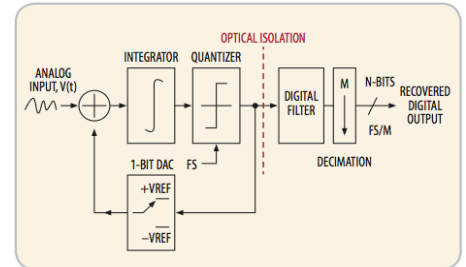

Figure 1. Optically isolated sigma delta modulator block diagram

Types of optically isolated modulators

There are two types of optically isolated sigma delta modulator; internally clocked and externally clocked. An externally clocked type has certain advantages over internally clocked type. For example, externally clocked type typically has a higher clock speed. The externally-clocked type also allows having a common master clock for easier data recovery and channel to channel synchronisation, for example simultaneous measurements of phase currents.

Speed and Precision

In motor or servo control, the motor loads being driven are inductive loads. From the inductor impedance equation below, one can deduce that voltage is dependent on the rate of change of the current flowing through the inductor.

$$V_L(t) = L \frac{di_L(t)}{dt}$$

Thus, fault conditions such as phase to phase shorts or ground shorts need to be detected and rectified as quickly as possible before dangerous voltage levels develop on the motor which could lead to catastrophic failures as well as human injury. Typical reaction time required for the motor controller to react to such fault is usually less than 10 μ sec. One common approach is to have separate filters with decimation ratios running in parallel (Figure 3). A filter can be configured with a smaller decimation ratio to provide the fast response required to track and react to fault conditions while having another filter

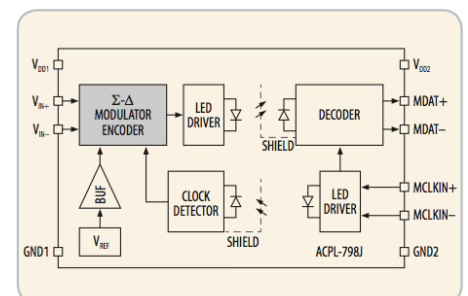

Figure 2. ACPL-798J block diagram

In-Circuit PCBA Test and In Line Automation

FREE Webinar

Attend to learn:

- Benefits of Automation
- How to Increase Productivity
- How to Lower Costs
- Automated Test ROI



Register Now!



Wednesday 1st October
15h00 CET

Decimation Ratio (R)	Fs = 20MHz			Fs = 10MHz		
	Throughput Rate (Fs/R) KHz	Effective Number of Bits (ENOB)	Filter Delay (μ s)	Throughput Rate (Fs/R) KHz	Effective Number of Bits (ENOB)	Filter Delay (μ s)
256	78.1	12	12.8	39.1	12	25.6
128	156.2	11	6.4	78.1	11	12.8
64	312.5	11	3.2	156.2	11	6.4
32	625	10	1.6	312.5	10	3.2

Table 1. Decimation ratio vs. filter delay time illustration & ENOB

in parallel with higher decimation ratio for better resolution during the normal control loop operation. By partitioning a system in such a way, it is possible to sense and react quickly to rectify any fault conditions. Table 1 shows the tradeoff between resolution and speed by selecting the appropriate decimation ratio.

Field safety and reliability

Avago optocouplers are certified to the IEC safety standard IEC60747-5-5 for Reinforced Insulation. This is a component safety standard designed to test the isolation construction, insulation material, and ageing mechanism of optocouplers: it is applicable to only optocouplers and is not applicable to alternative isolators.

As a compromise, some test houses offer certified compliance for alternative isolators to the optocoupler standard DIN/EN 60747-5-2 but have only issued certification of BASIC insulation, which implies a partial compliance but not a full certifica-

tion. That is because the quality and characteristics of such thin-film polyimide and CMOS insulation with respect to safe insulation application are not yet well understood. Avago has been manufacturing and supply-

ing in high volumes optically isolated modulators and isolation amplifiers to many motor control customers for over close to two decades. This track record is testament to the safety and reliability that optical isolation provides. Current measurement using optical isolated sigma delta modulators offers the flexibility of alternative configurations for precision and speed by choosing the appropriate filtering schemes. Only optocouplers are certified to the IEC Safety Standard IEC60747-5-5 for reinforced insulation: optically isolated modulators provide a field proven method to measuring current in an accurate, safe and reliable way.

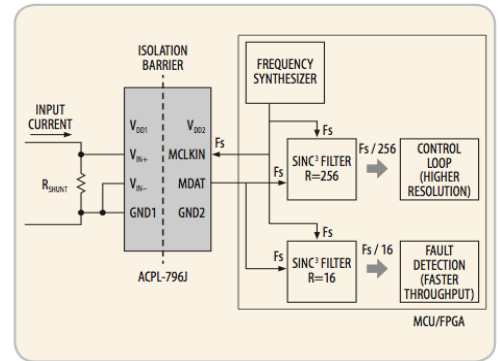

Figure 3. Decimation filter partitioning

PicoScope® PC-OSCILLOSCOPES



For every application there's a PicoScope

Bandwidth from 5 MHz to 1 GHz • Sampling from 10 MS/s to 5 GS/s • Memory from 8 ks to 2 GS

PICOSCOPE 6000 SERIES

Ultimate performance, now USB 3.0

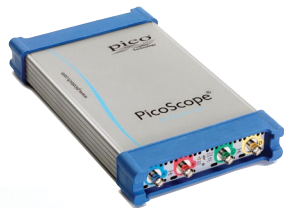

PICOSCOPE 5000 SERIES

Flexible resolution oscilloscopes



PICOSCOPE 4824

8 Channels, high resolution



PICOSCOPE 3400 SERIES

High-performance oscilloscopes



ALL MODELS INCLUDE FULL SOFTWARE AND 5 YEAR WARRANTY. SOFTWARE INCLUDES MEASUREMENTS, SPECTRUM ANALYZER, SDK, ADVANCED TRIGGERS, COLOR PERSISTENCE, SERIAL DECODING (CAN, LIN, RS232, I²C, I²S, FLEXRAY, SPI), MASKS, MATH CHANNELS, ALL AS STANDARD, WITH FREE UPDATES.

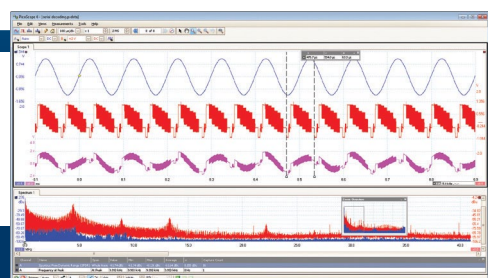

www.picotech.com/PS351

productroundup

16-bit ADC precision in industrial control MCUs

A single-core series of MCUs for industrial real-time control design, Texas Instruments' C2000 Delfino 32-bit F2837xS microcontrollers (MCUs) offer four 16-bit analogue-to-digital converters (ADCs), enabling precision feedback in power control applications. They are pin- and software-compatible with the recently introduced dual-core C2000 Delfino F2837xD MCUs. The Delfino F2837xS MCUs offer



a combination of C28x architecture and real-time control accelerator (CLA) that provides a combined 400 MIPS of floating-point performance, enabling management of multiple control tasks simultaneously. The C28x CPU is further accelerated for trigonometry and complex math operations: it can execute trigonometric-based algorithms used in transforms and control functions with the new trigonometric math unit (TMU) hardware accelerator integrated in the C28x core and automatically executed in the compiler. There is also a Viterbi Complex Unit (VCU II) hardware accelerator for comms functions, likewise automatically invoked in the compiler.

[Complete article, here](#)

ARM Cortex-M0 core in small package

Toshiba's TX100 low-pin-count ARM-core MCU integrates interfacing functions and contributes to lower manufacturing costs; TPM037FWUG is a microcontroller designed for motor control applications. Housed in an LQFP64 package measuring 10 x 10 mm, pin pitch 0.5 mm, the MCU has a low pin count of 64. It integrates an 8-channel 10-bit A/D converter and a 10-channel 16-bit timer with a Programmable Pulse Generator (PPG). The MCU also integrates a 6-channel serial interface (5 channel SIO/UART, 1 channel I₂C), which eliminates the need for interface extension ICs and also contributes to lower manufacturing cost. It also has a bit-band processing function that supports access and control of specific bits. This increases bit manipulation efficiency and allows optimisation of the product's small-capacity flash memory that comprises 128 kBytes NAND Flash and 16 kBytes SRAM.

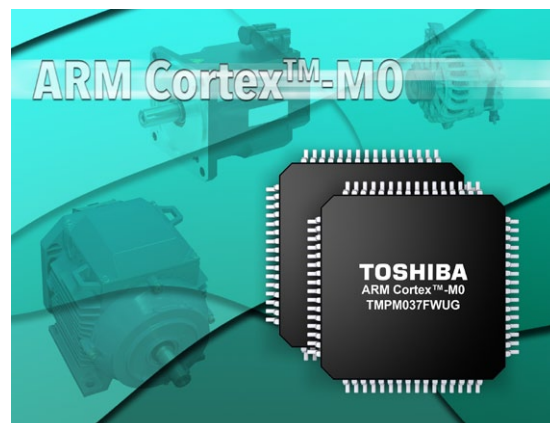

[Complete article, here](#)

2.4 GHz, 23 dBm RF amp for 256 QAM

SST12CP21 is a 2.4 GHz 256-QAM RF high-power amplifier from Microchip, that offers low EVM and current consumption for IEEE 802.11n systems. It delivers high linear output power of up to 23 dBm at 1.75% dynamic EVM, with MCS9 HT40 MHz bandwidth modulation at 5V and 320 mA current consumption. 25 dBm of linear power, at 3% EVM with 350 mA

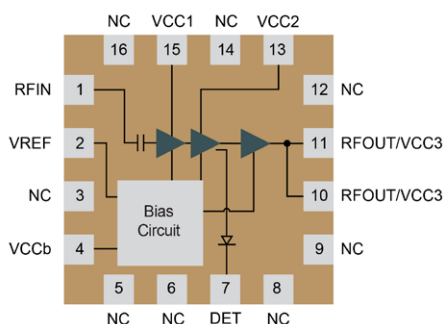

current consumption, is available for 802.11g/n applications. This performance extends the range of 802.11b/g/n WLAN and MIMO systems, while consuming low current at the maximum 256-QAM data rate. The SST12CP21 is also spectrum mask compliant up to 28 dBm for 802.11b/g communication. Board space is reduced by the 3 x 3 x 0.55 mm, 16-pin QFN package that matches a popular pin-out. It has 50Ω on-chip input match and simple output match: an integrated linear power detector provides accurate output power control over temperature and 2-to-1 output mismatch.

[Complete article, here](#)

38V step-down controller outputs 24V

LTC3807 is a low quiescent current synchronous step-down DC/DC controller that draws 50 μA in standby mode with the output voltage in regulation. The 4V to 38V input supply range is designed to protect against high voltage transients, continue operation during automotive cold crank and cover a broad range of input sources and battery chemistries. The output voltage can be set from 0.8V to 24V at output currents up to 25A with efficiencies as high as 95%, suiting it for automotive, heavy equipment, industrial and robotic applications. It has 1.1Ω on-chip MOSFET

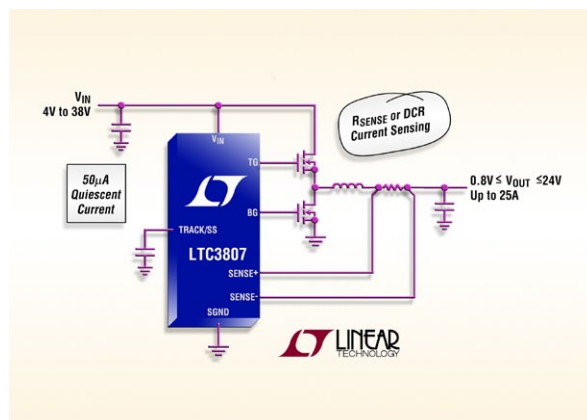

gate drivers, operates with a selectable fixed frequency between 50 kHz and 900 kHz and is synchronisable to an external clock ranging from 75 kHz to 850 kHz. Output current sensing is accomplished by measuring the voltage drop across the output inductor (DCR) for the highest efficiency or by using an optional sense resistor.

[Complete article, here](#)

IP builds sub-1V Bluetooth Smart RF transceiver

CSEM (Switzerland) has announced IcyTRX-65, a 2.4GHz silicon RF IP optimised for low power Bluetooth Smart (Bluetooth Low Energy) circuits, targeting wearable sensors and Internet-of-things. Consuming 5 mW and directly powered from a 1V battery, IcyTRX-65, says CSEM, sets a new benchmark for low power BLE circuits. IcyTRX-65 is a 65nm CMOS

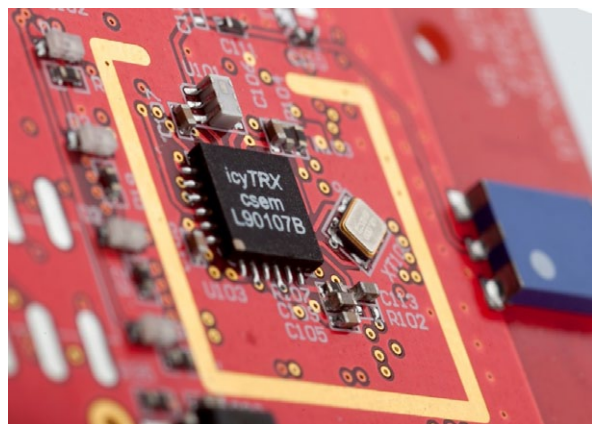

version of the IcyTRX IP, offering even lower-power performance: 5 mA current consumption directly from a 1V battery, sensitivity of -97 dBm and a transmitter frequency synthesiser settling time of 5 µsec, along with full BT4.1 compliance. IcyTRX-65

operates down to 0.9V, allowing the use of small coin-cell batteries. The architecture results in a highly integrated solution, with a die size of less than 2mm², and no external matching components required. A flexible and programmable baseband offers a programmable data-rate up to 4 MB/sec and allows use with IEEE802.15.4 protocols.

[Complete article, here](#)

Reversible debugger now has in-the-field edition

Undo Software has announced UndoDB Out-and-About, a new way of licensing its high-performance reversible debugging software. UndoDB Out-and-About is aimed at software vendors whose software is deployed on customer sites. This edition licenses the full capabilities of UndoDB to be used in the field on a customer machine, by the software vendor's engineers, to investigate, find and consequently fix customer-critical bugs. UndoDB Out-and-About helps track down software failures, such as intermittent issues and memory corruption errors, directly at the customer site. This protects brand reputation, reduces stress, and preserves customer relationships. It is particularly useful when customers do not want to send their highly confidential, mission-critical data off-site to the vendor for them to reproduce the bug. UndoDB Out-and-About provides exactly the same functionality as Undo Software's main product, UndoDB, but is licensed for use on a machine not owned by the licensee. Available on Linux and Android, UndoDB allows developers to record their program's execution and then rewind and replay their C/C++ code in real-time to find bugs more quickly, increasing productivity and helping to meet development deadlines.

[Complete article, here](#)

Frequency domain analysis for Keysight 'scopes

Keysight Technologies (the company formerly known as Agilent) has a frequency domain analysis (FDA) option, which it positions as the industry's first user-extensible spectrum frequency domain analysis application solution for real-time oscilloscopes.

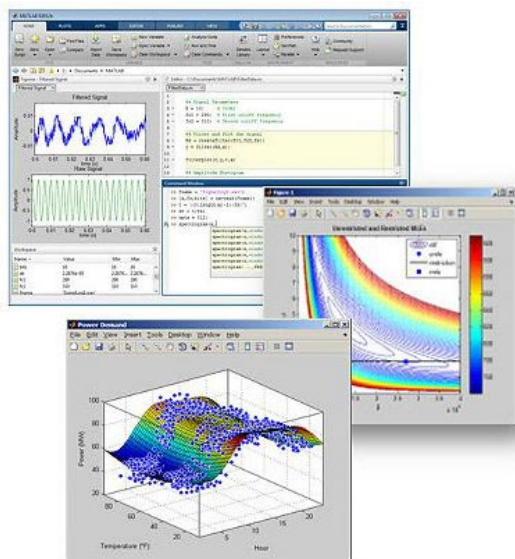

The FDA option extends the capabilities of Infiniium and InfiniiVision Series oscilloscopes by enabling engineers to acquire live signals from the oscilloscope and visualise them in the frequency domain as well as make key frequency domain measurements. Option N8832A-001 includes the application, the application source code for user extensibility, and MATLAB software. It provides power spectral density (PSD) and spectrogram visualisation, commonly found in spectrum analyser and frequency domain analysis software; frequency domain measurements in an

application including relevant peaks in the PSD and measurements such as occupied bandwidth, SNR, THD (total harmonic distortion), SFDR (spurious free dynamic range) and frequency error.

[Complete article, here](#)

Starterkits speed up safety standard compliance

Embedded Office is offering pre-certified components in the form of its Cert-Kits that support manufacturers of safety-relevant systems in accordance with the standards IEC62304, IEC61508 and EN50128 in standard-compliant development. The 'starterkits' are executable systems, which allow users to immediately commence the development of a certification project. The starterkits comprise the source code of a given microcontroller for the respective development tool. They are available for the real-time kernel µC/OS-II with memory protection, µC/OS-MPU, and for the partitioning system µC/TimeSpaceOS. The core of the starterkit is a component that comprises a flexibly deployable hardware programming interface from the respective product to the microcontroller employed using the respective development tools. The component can be adapted by configuring the hardware wiring of the microcontroller. It supports all the necessary units of a microcontroller for operating a random real-time kernel. Additional units are integrated in case the respective product should require these. The component has been prepared for use in safety-critical applications, meaning that mechanisms for monitoring the integrity are already integrated.

[Complete article, here](#)

Dual-mode Bluetooth Low-Energy modules

Distributor Digi-Key has announced a distribution agreement with BlueCreation, maker of dual-mode BLE solutions. Focused on enabling innovative devices integrating wireless technologies, BlueCreation specialises in the manufacture of Bluetooth, Bluetooth Low Energy, Wi-Fi and other embedded wireless solutions. The company has a Bluetooth Low Energy offering, providing a dual-mode BLE solution with concurrent stack that



can run both BLE and standard Bluetooth. BlueCreation's products provide easy-to-implement BLE solutions for a variety of application areas, including sensor networks, energy and equipment monitoring, and control, as well as numerous additional applications in the realm of the Internet of Things. Its newly released dual-mode BC127 module and development kits provide advanced features needed in the crowded connecting devices market, the company says.

[Complete article, here](#) 

Static analysis tool extends C++'11 code coverage

PRQA | Programming Research, provider of static analysis tools, has announced an upgrade to QA-C++. Version 3.2 is the most recent release of this static analysis tool for C++ environments. It incorporates new functionality. It delivers extended C++'11 coverage, improved enforcement of secure coding best practices, increased range of metrics and easier integration with auto-code generators. The tool is aimed directly at development teams that have transitioned to C++'11. The tool already provides coverage of key C++'11 constructs such as rvalue references and variadic templates. Version 3.2 further extends this coverage, adding user defined literals, the noexcept operator, alias templates, the constexpr keyword, alignof and alignas, inheriting and delegating constructors. To support the increasing requirement for the detection of security issues, QA-C++ now includes a pre-configured grouping which comprises security related rules, providing an easier mechanism to assess a source code's adherence to security related guidelines and best practices. The number of metrics produced by QA-C++ has effectively doubled from 26 to 53, and Version 3.2 provides 29 function-, 16 file- and 8 class-related metrics. QA-C++'s integration with auto-code generators, including Rhapsody, has also been improved.

[Complete article, here](#) 

AFE & ARM-core chip offers 16-bit measurements

Analog Devices has posted details of the ADuCM350, which is a complete, coin cell powered, high precision, meter-on-chip for portable device applications such as point-of-care diagnostics and body-worn devices for monitoring vital signs. The ADuCM350 is designed for high precision potentiostat, current, voltage, and impedance measurement capabilities. The device's analogue front end (AFE) features a 16-bit, precision, 160 ksamples/sec analogue-to-digital converter (ADC); 0.17% precision voltage reference; 12-bit, no missing codes digital-to-analogue converter (DAC); and a reconfigurable ultralow leakage switch matrix. It has four voltage measurement channels, up to eight current measurement channels and an impedance measurement DFT engine. The ADuCM350 also includes an ARM Cortex-M3-based processor, memory, and all I/O connectivity to support portable meters with display, USB communication, and active sensors. It is packaged in a 120-lead, 8 x 8 mm CSP BGA and operates from -40°C to +85°C. To support extremely low dynamic and hibernate power management, the ADuCM350 provides a collection of power modes and features, such as dynamic and software controlled clock gating and power gating. The analogue feature set includes analogue hardware accelerators; an autonomous analogue front-end (AFE) controller, direct digital synthesiser (DDS)/arbitrary waveform generator, receive filters, plus the complex impedance measurement (DFT) engine.

[Complete article, here](#) 

Small form factor GNSS module for tracking, automotive and wearable designs

Hong Kong based manufacturer of location receivers, Maestro Wireless Solutions, and CSR, have introduced the A5100-A, a next-generation SiRFstarV Global Navigation Satellite Systems (GNSS) positioning module that combines high performance GPS and GLONASS receiver technology in a 10 x 15 mm package. The A5100-A is suitable for applications including wearable devices, cameras and automotive trackers. It is the first release in Maestro's new line of GNSS receivers, and achieves high levels of accuracy with quad-constellation support, up to 30% faster Time-To-First-Fix (TTFF), and up to 20% lower power consumption using CSR's TricklePower and Push-to-Fix (PtF) modes. The module integrates TCXO, SAW filter, RTC, antenna control mechanism, and flash memory for future-proof upgrades, as well as, offering a drop-in replacement capability for Maestro's previous SiRFstar4 generation modules. The castellated edge form factor also enables simpler manufacturing.

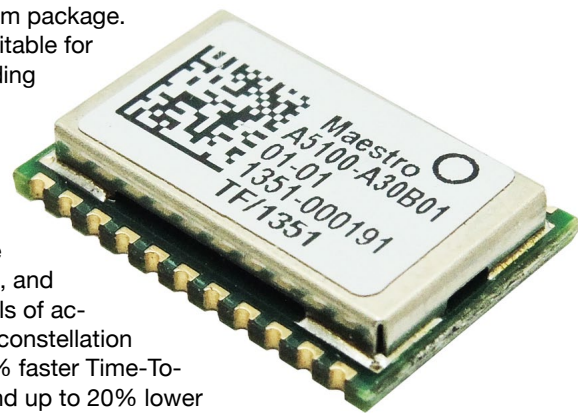

[Complete article, here](#) 

Current sensor ICs with high accuracy and internal isolation

ACS722 and ACS723 current sensor ICs from Allegro MicroSystems Europe are high-accuracy devices featuring



internal galvanic isolation, and are suited to use in low-power applications incorporating high output voltage swings at low currents. The devices are true bidirectional $\pm 5A$ or unidirectional 10A sensor ICs which provide an

economical and precise solution for AC or DC current sensing in non-automotive applications such as motor control, load detection and management, switched-mode power supplies, solar invertors and overcurrent fault protection. Each of the new ICs consists of a precise, low-offset, linear Hall sensor circuit with a copper conduction path located near the surface of the die. The output of the device has a positive slope when an increasing current flows through the primary copper conduction path. The internal resistance of this conductive path is typically 0.65 m Ω , providing low power loss.

[Complete article, here](#)

MEMS-resonator tracking tag with no electronics

Australian technology company, Bluechiip Limited and STMicroelectronics, have announced high-volume production for their jointly developed, MEMS-based tracking tags with the ability to meet demand in excess of 1 million tags a year. The Bluechiip tag is an ultra-high-integrity, all-mechanical tracking-chip that, unlike an electronic tag, is impervious to extreme high and low temperatures, gamma radiation, moisture, and other harsh conditions that would compromise traditional identification or tracking solutions such as labels, barcodes, or RFID technologies. This new chip uses MEMS resonator technology and contains no electronics whatsoever. Each chip is individually preprogrammed during manufacture with a unique identification, a process that also makes it tamper proof. The technology was initially developed for applications in the health-care and biomedical industries.



[Complete article, here](#)

Dual-power-MOSFET package cuts losses

International Rectifier's power block family of devices now includes the IRFHE4250D FastIRFET dual power MOSFET; it comprises the control and synchronous FETs for a synchronous buck converter in a single package. The new 25V device is targeted at 12V input DC-DC synchronous buck applications. The IRFHE4250D reduces power losses by more than 5% at 25A compared to conventional power block devices; it features

IR's latest-generation silicon and expands the power block packaging platform with a 6 x 6 mm PQFN package with exposed top and slim profile for back-side mounting that, combined with its thermal performance, low on-state resistance (RDS(on)) and gate charge (Qg) delivers improved power density and lower switching losses to shrink PCB size and improve overall system efficiency. At VDSS of 25V and VGS of 4.5V, the typical/maximum figures for on-resistance are 3.2/4.1 m Ω for the control FET, and 1.0/1.35 m Ω for the synchronous FET.



[Complete article, here](#)

Arduino libraries expand FTDI's EVE HMI

To provide further assistance to engineers using its Embedded Video Engine (EVE) technology, FTDI Chip can now supply a comprehensive suite of additional support facilities. These are designed to be utilised with both the established FT800 graphic controller IC and the newly announced FT801, with capacitive touch enabled interface and multi-touch capabilities. The EVE Emulator Library is a behaviour modelling software tool through which engineers can emulate the display and touch functions of the FT800 (and in the near future, for the FT801 in single touch rather than multi-touch mode) without the need for any hardware. The EVE Screen Editor is a Windows-based software tool which enables engineers to study display commands and experiment with generating their own display lists by which to control EVE ICs: and Arduino libraries offered by FTDI Chip to accompany its EVE offering have been updated for the FT800 and FT801 controller devices.



[Complete article, here](#)

If you can't have the parts you want, use the parts you have

Years ago I ran into a problem, which was solved by taking advantage of the voltage offset in an op-amp.

I was working as a spacecraft technician at the time and our test group was preparing a satellite for a thermal-vacuum test. During this test the completed satellite was installed in a large vacuum chamber. There were panels installed on the walls of the chamber, which would be filled with liquid nitrogen after the chamber was pumped down to a vacuum. This would simulate the thermal conditions in orbit.

The test had two purposes. First, was to verify all of the electronic systems operated correctly in a vacuum. The second and most important was to check the thermal control systems to verify that all components and structures remained within the specified temperature limits.

Compartments with heat generating equipment had exterior heat radiating surfaces to keep things cool and heaters to keep things warm when the equipment was off. All of the heaters were controlled by bi-metal thermostat switches that connected one terminal of the heater to the satellite main power bus. The other heater terminal returned to the bus return through a small value shunt resistor. A small voltage across this shunt resistor verified that the heater was drawing current and was operational.

A thermal design group monitored the satellite during the thermal-vacuum test with their own computers and recording equipment. They monitored temperatures from satellite telemetry and from many thermistors, which they installed. Also monitored were the heater shunt resistors to verify that the heaters were coming on at the correct temperature and drawing the correct amount of current.

There was a problem with the wiring on one heater. Somehow the current sense shunt resistor had been wired to the high side of the heater between the heater terminal and the thermostat switch. When that heater turned on, the shunt resistor was connected to the main bus voltage of about 30V.

The thermal group's monitoring system was designed to sense a few millivolts across the heater shunts with one side grounded. The 30V on the shunt was well beyond the limits of their equipment. The heater miss-wire would

not affect the heater operation in orbit so management decided not to rework the wiring harness. They decided that the thermal people could work around the problem some way.

The thermal group wanted their data on all heaters so I thought I would try to help them out. There were only a few days to do something before the test started so there was no time to order any special parts. The company stocked a few parts so I had to go with what was available.

I figured I would need a good differential amplifier to sense the few millivolts across the shunt while rejecting 30V common mode. The best op-amps available were 301s and there were also 1% resistors. I obtained twenty 100k resistors and ten 301 op-amps from company stores. From this collection I could select four resistors and two op-amps.

Other parts needed to complete the project were obtained from a nearby electronics surplus store and from my own home junk box. A differential amplifier was built on a perf board with four 100k 1% resistors and a 1k trim pot in series with the resistor to a common ground which also connected to the power supplies' returns, the satellite structure, and a signal return to the thermal group's computer.

Several op-amps were tested to find one with less than 2 mV offset. The common mode rejection was adjusted to be as high as possible by connecting the two input resistors together and connecting them to a 30V power supply through a resistor. A signal generator was connected through a DC blocking capacitor and several volts AC was applied to the amplifier input resistors. The trim pot was adjusted to null out any output at the amplifier output.

Trim pots drift and their set value can change with shock so a very small value compared with the 100k resistors was chosen to fine-tune the common mode rejection. The value was so small that the 100k resistors had to be selected to be able to adjust the common mode rejection.

The heater shunt circuit was mocked up and the differential amp would output -2 mV with power off and 15 mV with power on, on the heater mockup. The differential amplifier output was connected to the inverting input of a second 301 op-amp, which was used as a comparator. The op-amp used as a comparator

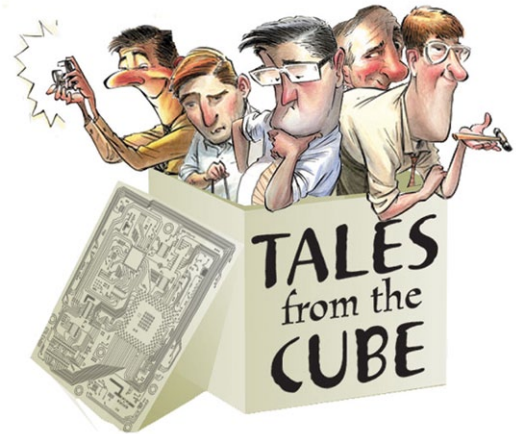

was selected to have the highest offset voltage of all tested. The op-amp used as a comparator had an offset voltage of +6 mV. This gave a window of 8 mV below its transition voltage when the heater was off and 9 mV above the transition point when the heater was on.

With the satellite heater on, the comparator output was -5V and with the satellite heater off the comparator output was +20V. To keep the offset voltages of the two op-amps from drifting, no offset compensation resistors were used on the differential amplifier and no hysteresis resistors were used on the amplifier that was used as a comparator. The circuit was powered by a simple power supply providing -5 and +20V.

During operation the voltage appearing at the differential amplifier input pins would vary from 0 with the heater off to +15V with the heater on. By using these supply voltages, the input pins would never be closer to the power supply rails than 5V. The power supply rejection ratio of these op-amps of 70 to 96 dB took care of any ripple on the simple power supply outputs. The output of the comparator was connected to a 10k current limiting resistor and the output was clamped with a 5V Zener, providing a -0.6 to +5V signal to the thermal group's computer.

A two minute warm-up time was required for the circuit to work correctly after a cold start. The thermal-vacuum test lasted for two weeks and the circuit worked perfectly during that period, making the thermal group happy. By selecting not-precision resistors and inexpensive op-amps, and keeping trimming to a minimum, it was possible to extract a 15 mV signal floating on 30V.